

# BANDSAW BLADES



## GLADIATOR TRIPLE TEMPERED M42 HIGH SPEED STEEL WITH 8% COBALT

**WELDED TO LENGTH!**

A high performance bi-metal band saw blade with a uniquely designed tooth edge that allows the teeth to cut in a fast, pulsating action. Ideal for large solid sections of exotic and nickel based alloys and high hardness steels

**Features:**

- Electron beam welded bi-metal construction
- Gladiator™ tooth design with variable tooth height and set
- Triple tempered M-42, cobalt high speed steel teeth,
- Hardness Rockwell C67-69
- Fatigue resistant alloy steel backing strip
- Aggressive "surging" cutting action
- Greater wear and heat resistance

Width	Thickness	Tooth Type	TPI	Part Number	Price Per Foot	Weld Charge
3/4	0.035	Vari-pos	4/6/P	SR-GLAD-99902	\$3.43	\$6.30
	0.035	Vari-pos	5/8/P	SR-GLAD-99903	\$3.43	\$6.30
	0.035	Vari-pos	6/10/P	SR-GLAD-99904	\$3.43	\$6.30
1	0.035	Vari-pos	2/3	SR-GLAD-99905	\$3.99	\$7.00
	0.035	Vari-pos	3/4	SR-GLAD-99906	\$3.99	\$7.00
	0.035	Vari-pos	4/6/P	SR-GLAD-99907	\$3.99	\$7.00
	0.035	Positive	5/8/P	SR-GLAD-99908	\$3.99	\$7.00
	0.035	Variant	6/10/P	SR-GLAD-99909	\$3.99	\$7.00
1-1/4	0.042	Vari-pos	2/3/P	SR-GLAD-99912	\$4.90	\$8.05
	0.042	Vari-pos	3/4/P	SR-GLAD-99913	\$4.90	\$8.05
	0.042	Vari-pos	4/6/P	SR-GLAD-99914	\$4.90	\$8.05
	0.050	Vari-pos	5/8/P	SR-GLAD-99915	\$4.90	\$8.05
1 1/2	0.050	Vari-pos	2/3/P	SR-GLAD-99923	\$6.30	\$8.05
	0.050	Vari-pos	3/4/P	SR-GLAD-99924	\$6.30	\$8.05
	0.050	Vari-pos	4/6/P	SR-GLAD-99926	\$6.30	\$8.05
2	0.062	Hook	2/3/P	SR-GLAD-99932	\$9.10	\$9.80
	0.062	Vari-pos	3/4/P	SR-GLAD-99933	\$9.10	\$9.80

**Tooth Set:**

- P=** Positive Rake-For cutting of solids
- S=** Straight (0°) Rake-For all material shapes
- W=** Wavy Set (0° Rake)-Light duty for tubing, pipe and light duty sawing applications

## FLEX-BACK HARD EDGE, FLEXIBLE BACK



**WELDED TO LENGTH!**

Ideal for wood and metal cutting, Flex-Back, made from carbon steel with a flexible back, is recommended for general purpose cutting on easy-to-machine ferrous metal.

**Features:**

- Economical, general purpose cutting
- Can be welded on standard welding equipment
- Ideal for both contour and straight cutting
- For Light to medium, vertical and horizontal machines
- Suited for low alloy, non-ferrous metal, furniture, composition board, plastics and nonferrous foundry materials

**Tooth Set:**

- P=** Positive Rake-For cutting of solids
- S=** Straight (0°) Rake-For all material shapes
- W=** Wavy Set (0° Rake)-Light duty for tubing, pipe and light duty sawing applications
- HP=** High profile teeth

Width	Thickness	Tooth Type	TPI	Part Number	Price Per Foot	Weld Charge
3/16	0.025	Skip	4/S-K	SR-HEFB-91080	\$0.73	\$5.60
	0.025	Regular	10/S	SR-HEFB-91090	\$0.73	
	0.025	Regular	14/S	SR-HEFB-91100	\$0.73	
1/4	0.025	Skip	4/P-HP	SR-HEFB-91130	\$0.65	\$5.60
	0.025	Hook	4/S	SR-HEFB-91120	\$0.65	
	0.025	Skip	6/S-K	SR-HEFB-91140	\$0.65	
	0.025	Hook	6/P-HP	SR-HEFB-91147	\$0.65	
	0.025	Regular	10/S	SR-HEFB-91161	\$0.65	
	0.025	Regular	14/S	SR-HEFB-91181	\$0.65	
	0.025	Regular	18/W	SR-HEFB-91190	\$0.65	
	0.025	Regular	24/W	SR-HEFB-91204	\$0.65	
	0.025	Regular	32/W	SR-HEFB-91210	\$0.65	
3/8	0.025	Hook	3/P-LP	SR-HEFB-91230	\$0.68	\$5.60
	0.025	Skip	4/S-K	SR-HEFB-91240	\$0.68	
	0.025	Hook	4/P-HP	SR-HEFB-91250	\$0.68	
	0.025	Skip	6/P-HP	SR-HEFB-91264	\$0.68	
	0.025	Hook	6/S	SR-HEFB-91261	\$0.68	
	0.025	Hook	8/S	SR-HEFB-91271	\$0.68	
	0.025	Regular	10/S	SR-HEFB-91281	\$0.68	
	0.025	Regular	14/S	SR-HEFB-91291	\$0.68	
	0.025	Regular	18/W	SR-HEFB-91300	\$0.68	
0.025	Regular	24/W	SR-HEFB-91307	\$0.68		
1/2	0.025	Wavy	14/W	SR-HEFB-91411	\$0.69	\$5.60
	0.025	Wavy	18/W	SR-HEFB-91420	\$0.69	
	0.025	Hook	3/P-LP	SR-HEFB-91330	\$0.69	
	0.025	Hook	4/S	SR-HEFB-91340	\$0.69	

Width	Thickness	Tooth Type	TPI	Part Number	Price Per Foot	Weld Charge
1/2	0.025	Hook	4/P-HP	SR-HEFB-91350	\$0.69	\$5.60
	0.025	Regular	6/P-HP	SR-HEFB-91373	\$0.69	
	0.025	Skip	6/S	SR-HEFB-91361	\$0.69	
	0.025	Regular	10/S	SR-HEFB-91380	\$0.69	
	0.025	Wavy	10/W	SR-HEFB-91390	\$0.69	
	0.025	Regular	14/S	SR-HEFB-91401	\$0.69	
	0.025	Wavy	14/W	SR-HEFB-91411	\$0.69	
	0.025	Regular	18/W	SR-HEFB-91420	\$0.69	
	0.025	Regular	24/W	SR-HEFB-91430	\$0.69	
	5/8	0.032	Regular	10/S	SR-HEFB-91450	
0.032		Regular	14/S	SR-HEFB-91471	\$0.90	
3/4	0.032	Skip	3/S	SR-HEFB-91510	\$0.97	\$5.60
	0.032	Hook	3/P-LP	SR-HEFB-91515	\$0.97	
	0.032	Skip	4/P-LP	SR-HEFB-91528	\$0.97	
	0.032	Regular	6/S	SR-HEFB-91531	\$0.97	
	0.032	Hook	6/P-HP	SR-HEFB-91542	\$0.97	
	0.032	Regular	8/S	SR-HEFB-91550	\$0.97	
	0.032	Regular	10/S	SR-HEFB-91570	\$0.97	
	0.032	Regular	14/S	SR-HEFB-91621	\$0.97	
1	0.035	Skip	3/P-LP	SR-HEFB-91689	\$1.16	\$5.95
	0.035	Hook	3/S-K	SR-HEFB-91680	\$1.16	
	0.035	Regular	6/S	SR-HEFB-91701	\$1.16	
	0.035	Regular	8/S	SR-HEFB-91720	\$1.16	
	0.035	Regular	10/S	SR-HEFB-91730	\$1.16	
1-1/4	0.035	Regular	14/S	SR-HEFB-91761	\$1.16	\$5.95
	0.042	Hook	WP-1-1/4/P	SR-HEFB-91990	\$2.24	

**Call Us Or Visit Our Website For Our Complete Selection!**

# KNURLING TOOLS

## CNC MODULAR KNURLING TOOL SHANK

- Specifically designed for the CNC Lathe.
- Precision square shank with preset center height.
- Right or Left hand applications.
- One shank fits all heads.
- One head fits all shanks.
- Cobalt knurl wheels, Tin-c coated.
- Carbide knurl pin.
- Easy set-up.
- Center height adjustment.
- Interchangeable knurl heads.
- High productivity.
- Best knurl quality.
- Long knurl wheel life.
- Low production cost.

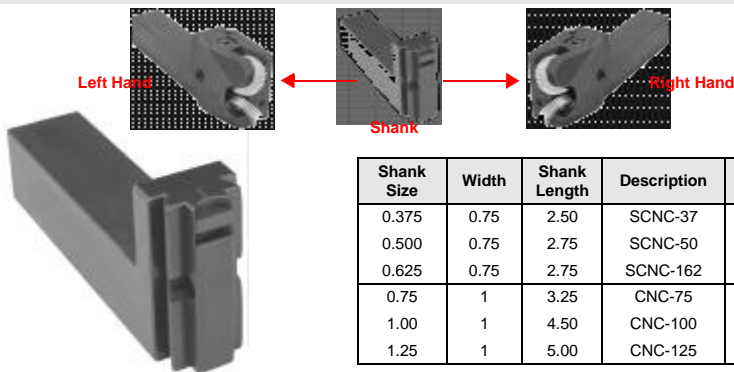

Shank Size	Width	Shank Length	Description	Part Number	Price Each
0.375	0.75	2.50	SCNC-37	DN20310	\$222.60
0.500	0.75	2.75	SCNC-50	DN20320	\$249.10
0.625	0.75	2.75	SCNC-162	DN20325	\$265.00
0.75	1	3.25	CNC-75	DN21010	\$710.20
1.00	1	4.50	CNC-100	DN21020	\$747.30
1.25	1	5.00	CNC-125	DN21030	\$795.00

## CNC MODULAR KNURLING TOOL HEADS

### Type 1 Small Diameter

#### Diamond Cutting Knurling Head

- Cutting Style
- Small Diameter Range
- Diamond Pattern Only
- End Feed
- Feed Range: .004 to .012



Description	Part Number	Price Each	Knurl Wheel	Dia. Range	Knurl Pin Desc.	Part Number	Price Each
SCNCKH-1-2	DN20335	\$265.00	SW2S	.312-1.5	PSW-2.0S	DN29005	\$31.32
CNCKH-1-2	DN21035	\$355.00	SW2S	.312-1.5	PSW-2.0S	DN29005	\$31.32



### Type 2 Heavy Duty

#### Diamond Cutting Knurling Head

- Cutting Style
- Medium Diameter Range
- Diamond Pattern Only
- End Feed
- Feed Range: .004 to .016



Description	Part Number	Price Each	Knurl Wheel	Dia. Range	Knurl Pin Desc.	Part Number	Price Each
CNCKH-2-R	DN21040	\$385.00	R	1.0-5.0	KPS-25-87-C	DN28925	\$14.31



### Type 3 Extra Heavy Duty

#### Diamond Cutting Knurling Head

- Cutting Style
- Large Diameter Range
- Diamond Pattern Only
- End Feed
- Feed Range: .004 to .025



Description	Part Number	Price Each	Knurl Wheel	Dia. Range	Knurl Pin Desc.	Part Number	Price Each
CNCKH-3-M	DN21045	\$460.00	M	2.0-up	KPS-31-100-C	DN28945	\$14.95



### Type 5 Single Wheel

#### Forming Knurling Head

- Forming Style
- Unrestricted Dia. Range
- Straight Pattern
- Male Diamond Pattern
- Female Diamond Pattern
- In Feed and End Feed



Description	Part Number	Price Each	Knurl Wheel	Dia. Range	Knurl Pin Desc.	Part Number	Price Each
CNCKH-5-O	DN21050	\$324.00	O	N/A	KPS-31-125-C	DN28950	\$15.79



### Style 6 Shoulder

#### Forming Knurling Head

- Forming Style
- 5/16" & Up Dia. Range
- Shoulder Knurling
- Straight Pattern
- Male Diamond Pattern
- In Feed and End Feed



Description	Part Number	Price Each	Knurl Wheel	Dia. Range	Knurl Pin Desc.	Part Number	Price Each
SCNCKH-6-2	DN20340	\$275.00	SW2	.312 & up	SW2.0P-2S	DN29055	\$31.32
CNCKH-6-4	DN21056	\$375.00	SW4	.312 & up	SW4.0P-2S	DN29085	\$36.72



### Style 7 Straddle Forming Knurling Head

#### Forming Style

- Up to 1" Dia. Range
- Straddle Knurling
- Straight Pattern
- Male Diamond Pattern
- In Feed and End Feed



Description	Part Number	Price Each	Knurl Wheel	Dia. Range	Knurl Pin Desc.	Part Number	Price Each
SCNCKH-7-D	DN20345	\$298.00	D	0.5	KPS-18-50-C	DN28905	\$11.45
CNCKH-7-R	DN21060	\$435.00	R	1	KPS-25-62-C	DN28915	\$12.30



Call Us Today For All Of Your Machine Tool Needs!

# KNURLING TOOLS



## Precise Adjustable Center Height

The dovetail mounting of the shank and head insures that the tool will be rigid and adjustable yet easy to use. By turning the adjustment screw clockwise or counterclockwise the center height of the head can be adjusted. Each eighth turn of the screw, which is marked on the screw, moves the head .004". After the desired center height has been reached, tightening the lock screw ensures that the head will remain in position while knurling a part.

## Method of Knurling

Knurl forming action displaces the material creating a perfect knurl pattern while sacrificing speeds and feeds. The force applied through forming is increased in larger diameters making knurling difficult and slow. Knurling cutting action cuts a perfect knurl pattern 10 to 20 times faster than a forming knurl tool becoming applicable for CNC use. It is engineered to knurl any material, including thin wall tubing, with minimum stress to the spindle and compound lathe.

## Modular Versatility

The CNC Modular Knurling Tool is a tooling system which combines exceptional versatility, rigidity, ease of handling, and simplicity. Knurl wheels, heads, and shanks can be combined to build your own knurling tool to fit any work application and machine.

- Precision square shank with preset center height.
- Right or Left hand applications.
- One shank fits all heads.
- One head fits all shanks.
- Easy set-up.
- Center height adjustment.
- Interchangeable knurl heads.
- High productivity.
- Best knurl quality.
- Low production cost.
- Cutting - 10 to 20 times faster.

## CUTTING

### CNC-000-1-2

#### Small cutting range: 5/16" to 1-1/2"

Minimum stress on the machine, and faster than knurl forming action. Twin straight SW series knurl wheels for diamond pattern. Allows tool to knurl close to a square shoulder. Supplied with SW2S-30C cobalt knurl wheels-Tin-c coated. Adds longer life and better performance to the knurl wheels.



Description	Shank Size	Tool Length	Part Number	Price Each
SCNC-37-1-2	0.375	4.125	DN20010	\$445.20
SCNC-50-1-2	0.5	4.375	DN20020	\$487.60
SCNC-162-1-2	0.625	4.375	DN20025	\$524.70
CNC-75-1-2	0.75	5.5	DN20410	\$629.64
CNC-100-1-2	1	6.75	DN20420	\$687.94
CNC-125-1-2	1.25	7.25	DN20430	\$731.40

## CUTTING

### CNC-000-2-R

#### Heavy duty cutting range: 1" to 5"

Minimum stress on the machine, and faster than knurl forming action. Twin straight R series knurl wheels for diamond pattern. Supplies more rigidity for larger diameters. Knurl wheels are mounted between thrust washers. Ensures smooth and even rotation of the knurls. Supplied with RS-25-C cobalt knurl wheels - Tin-c coated. Adds longer life and better performance to the knurl wheels.



Description	Shank Size	Tool Length	Part Number	Price Each
CNC-75-2-R	0.75	5.5	DN20510	\$739.88
CNC-100-2-R	1	6.75	DN20520	\$784.40
CNC-125-2-R	1.25	7.25	DN20530	\$837.40

## CUTTING

### CNC-000-3-M

#### Extra heavy duty cutting range: 1-1/2" & up

Minimum stress on the machine, and faster than knurl forming action. Twin straight M series knurl wheels for diamond pattern. Supplies more rigidity for larger diameters. Knurl wheels are mounted between thrust washers. Ensures smooth and even rotation of the knurls. Supplied with MS-25-C cobalt knurl wheels - Tin-c coated. Adds longer life and better performance to the knurl wheels.



Description	Shank Size	Tool Length	Part Number	Price Each
CNC-75-3-M	0.75	5.625	DN20610	\$697.48
CNC-100-3-M	1	6.875	DN20620	\$731.40
CNC-125-3-M	1.25	7.375	DN20630	\$773.80

## FORMING

### CNC-000-5-0

#### Straight bump

Great quality of knurl pattern. Single O series knurl wheel for straight or diamond pattern. Narrow knurl applications, up to 3/8" wide. Knurl wheel is mounted between thrust washers. Ensures smooth and even rotation of the knurl. Supplied with ODF-25-C cobalt knurl wheel - Tin-c coated. Adds longer life and better performance to the knurl wheel.



Description	Shank Size	Tool Length	Part Number	Price Each
CNC-75-5-0	0.75	5.5	DN20710	\$621.16
CNC-100-5-0	1	6.75	DN20720	\$646.60
CNC-125-5-0	1.25	7.25	DN20730	\$680.52

## FORMING

### CNC-000-6

#### Shoulder diameter range: 5/16" & up

Better quality of knurl pattern. Twin SW series knurl wheels for straight or diamond pattern. Allows tool to knurl against a square shoulder. A thrust washer is mounted between the knurls and tool head. Ensures smooth and even rotation of the knurls. Supplied with SW2R/L-30C or SW4R/L-25C cobalt knurl wheels - Tin-c coated. Adds longer life and better performance to the knurl wheels.



Description	Shank Size	Tool Length	Part Number	Price Each
SCNC-37-6-2	0.375	4.125	DN20110	\$445.20
SCNC-50-6-2	0.5	4.375	DN20120	\$487.60
SCNC-162-6-2	0.625	4.375	DN20125	\$524.70
CNC-75-6-4	0.75	5.5	DN20811	\$658.00
CNC-100-6-4	1	6.75	DN20821	\$690.00
CNC-125-6-4	1.25	7.25	DN20831	\$730.00

## FORMING

### CNC-000-7

#### Small diameter range: up to 1"

Better quality of knurl pattern. Compact design. Allows more clearance for the tool head. Twin D or R series knurl wheels for straight or diamond pattern. Supplies more rigidity for compact design. Supplied with DDR/L or RDR/L-30-C cobalt knurl wheel - Tin-c coated. Adds longer life and better performance to the knurl wheel. Self-centering knurling head. Precise alignment to the working part.



Description	Shank Size	Tool Length	Part Number	Price Each
SCNC-37-7-D	0.375	4.25	DN20210	\$492.90
SCNC-50-7-D	0.5	4.5	DN20220	\$519.40
SCNC-162-7-D	0.625	4.5	DN20225	\$561.80
CNC-75-7-R	0.75	5.75	DN20910	\$710.20
CNC-100-7-R	1	7	DN20920	\$747.30
CNC-125-7-R	1.25	7.5	DN20930	\$795.00

Call Us Or Visit Our Website For Our Complete Selection!

## 107ST - Straight Cutting Knurling Tool for CNC Lathe

Specifically designed for CNC lathe. Precision square shank with preset center height. Single knurl wheel set at 30° to cut a straight pattern. The knurl wheel is mounted between the thrust washers to ensure a smooth and even rotation of the knurl while knurling is performed. Rotate knurl head for a precise alignment to the working part.

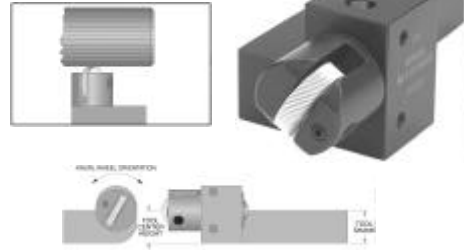

Center Height	Shank Size	R.H. Desc.	Part Number	Price Each	Knurl Wheel	Knurl Pin Set	Part Number	Price Each
0.500	.500x.500	107ST-50-R-RH	DN21110	\$328.60	RDL-30-C	KPS-25-100-C	DN28930	\$12.83
0.625	.625x.625	107ST-162-R-RH	DN21115	\$418.70				
0.750	.750x.750	107ST-75-M-RH	DN21130	\$418.70	MDL-25-C	KPS-31-125-C	DN28950	\$15.79
1.000	1.00x1.00	107ST-100-M-RH	DN21140	\$461.10				
1.250	1.25x1.25	107ST-125-M-RH	DN21150	\$503.50				

## 3SHKT - Three Swivel Head Knurling Tool

Designed to quickly knurl multiple applications with one tool. Precision square shank with preset center height. Twin knurl wheels for straight and diamond pattern. Knurl wheels are mounted between the thrust washers to ensure a smooth and even rotation of the knurls while knurling is performed. Self-centering knurling head for a precise alignment to the working part.

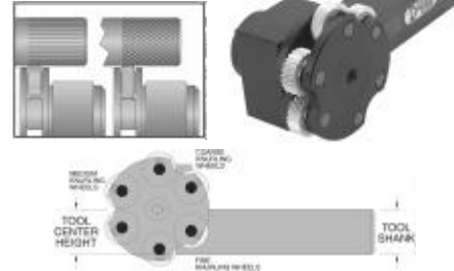

Center Height	Shank Size	Desc.	Part Number	Price Each	Knurl Wheel	Knurl Pin Set	Part Number	Price Each
0.500	.500 x .750	3SHKT-50-D	DN21510	\$275.60	DDR/L-20-C	KPS-18-50	DN28805	\$6.68
0.625	.625 x .750	3SHKT-162-D	DN21515	\$275.60	DDR/L-30-C DDR/L-40-C			
0.750	.750 x 1.00	3SHKT-75-M	DN21530	\$312.70	MDR/L-16-C	KPS-31-100	DN28845	\$7.42
1.000	1.00 x 1.00	3SHKT-100-M	DN21540	\$349.80	MDR/L-25-C			
1.250	1.25 x 1.25	3SHKT-125-M	DN21550	\$392.20	MDR/L-35-C			

## SCK - Self-Centering Knurling Tool for CNC Lathe

Specifically designed for CNC lathe. Precision square shank with preset center height. Twin knurl wheels for straight and diamond pattern. Knurl wheels are mounted between the thrust washers to ensure a smooth and even rotation of the knurls while knurling is performed. Self-centering knurling head for a precise alignment to the working part.



Center Height	Shank Size	Desc.	Part Number	Price Each	Knurl Wheel	Knurl Pin Set	Part Number	Price Each
0.500	.500 x .750	SCK-50-D	DN22110	\$206.70	DDR/L-30-C	KPS-18-50	DN28805	\$6.68
0.750	.750 x 1.25	SCK-75-M	DN22120	\$249.10	MDR/L-25-C	KPS-31-75	DN28840	\$7.42
1.000	1.00 x 1.25	SCK-100-M	DN22130	\$280.90				
1.250	1.25 x 1.25	SCK-125-M	DN22140	\$312.70				

## SSCK - Shoulder Self-Centering Knurling Tool for CNC Lathe

Specifically designed for CNC lathe. Designed to knurl against a square shoulder. Precision square shank with preset center height. Twin knurl wheels for straight and diamond pattern. Knurl wheels are mounted between thrust washers to ensure smooth and even rotation of the knurls while knurling is performed. Supplied with Cobalt TIC/N coated SW series knurl wheels. Self-centering knurling head for a precise alignment to the working part.

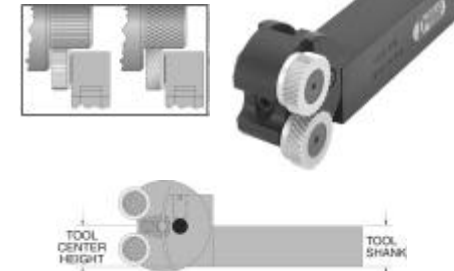

Center Height	Shank Size	Desc.	Part Number	Price Each	Knurl Wheel	Knurl Pin Set	Part Number	Price Each
0.375	.375 x .500	SSCK-38-2	DN22210	\$302.10	SW2-S/R/L	SW2.0P-2S	DN29055	\$31.32
0.500	.500 x .625	SSCK-50-2	DN22220	\$302.10	SW3.5-S/R/L	SW3.5P-2S	DN29070	\$34.56
0.750	.750 x .750	SSCK-75-3	DN22230	\$365.70				
0.750	.750 x .750	SSCK-75-4	DN22240	\$365.70				
1.000	1.00 x 1.00	SSCK-100-4	DN22250	\$365.70	SW4-S/R/L	SW4.0P-2S	DN29085	\$36.72
1.250	1.25 x 1.25	SSCK-125-4	DN22260	\$397.50				

## SWFKT - Single Wheel Fixed Knurling Tool for Manual or CNC Lathes

Precision square shank with preset center height. Single knurl wheel for straight and diamond pattern. Knurl wheel is mounted between the thrust washers to ensure smooth and even rotation of the knurl while knurling is performed. Best used for straight patterns or bump knurling a diamond pattern.

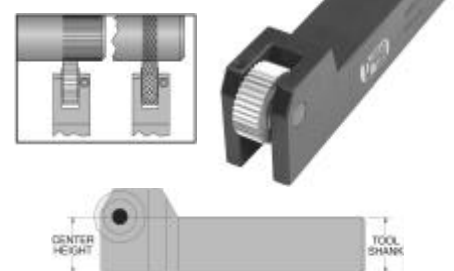

Center Height	Shank Size	Desc.	Part Number	Price Each	Knurl Wheel	Knurl Pin Set	Part Number	Price Each
0.375	.375x.375	SWFKT-38-D	DN21720	\$76.32	DS-30-C	KPS-18-50	DN28805	\$6.68
0.500	.500x.500	SWFKT-50-D	DN21730	\$76.32	DS-30-C	KPS-18-50	DN28805	\$6.68
0.750	.750x.750	SWFKT-75-M	DN21740	\$97.52	MS-25-C	KPS-31-75	DN28840	\$7.42
1.000	1.00x1.00	SWFKT-100-O	DN21750	\$108.12	OS-25-C	KPS-31-100	DN28845	\$7.42
1.250	1.25x1.25	SWFKT-125-O	DN21760	\$125.08	OS-25-C	KPS-31-125	DN28850	\$7.53

Call Us Today For All Of Your Machine Tool Needs!

## FACEKT - Face Knurling Tool for Manual or CNC Lathes

Designed to knurl small width face knurl patterns, even up to a shoulder. Precision square shank with preset center height. Single knurl wheel for straight and diamond pattern. Knurl wheel is mounted on the thrust washer to ensure smooth and even rotation of the knurl while knurling is performed. Reversible for right or left hand operation.

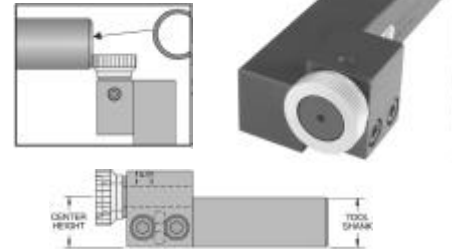

Center Height	Shank Size	Description	Part Number	Price Each	Knurl Wheel	Knurl Pin Set	Part Number	Price Each
0.500	.500x.500	FACEKT-50-2	DN21610	\$196.10	SW2S-30-C	SW2.0P-1S	DN29050	\$15.66
0.750	.750x.750	FACEKT-75-2	DN21620	\$217.30				
1.000	1.00x1.00	FACEKT-100-2	DN21630	\$217.30				
0.750	.750x.750	FACEKT-75-4	DN21640	\$249.10	SW4S-25-C	SW4.0P-1S	DN29080	\$18.36
1.000	1.00x1.00	FACEKT-100-4	DN21650	\$249.10				

Supplied with one 30 or 25 TPI knurling wheels for straight pattern

## CNC109 - Side Mount Straddle Knurling Tool for Manual or CNC Lathe

The shank is mounted on the side of the tool allowing for less tool projection from the turret on a CNC. Designed for when pressure and deflection are a problem. The knurling heads are able to "float" somewhat and center on the workpiece, compensating for any off-centering. Precise square shank with preset center height. Diametrical adjustment screw regulates the depth of the knurl pattern and diameter size.

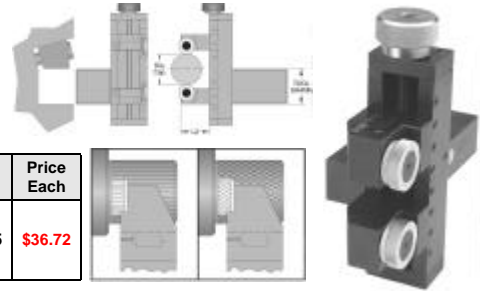

Center Height	Shank Size	Cap.	L2	R.H. Description	Part Number	Price Each	Knurl Wheel	Knurl Pin Set	Part Number	Price Each
0.750	.750x1.00	Up	1.625	CNC109-75-2-4-RH	DN21310	\$405.98	SW4-S/R/L	SW4.0P-2S	DN29085	\$36.72
1.000	1.00x1.00	to	1.625	CNC109-100-2-4-RH	DN21320	\$419.76				
1.250	1.25x1.25	2	1.625	CNC109-125-2-4-RH	DN21330	\$527.88				

## KTW109 - Diametral Shoulder Knurling Tool with Self-Centering Adjustable Floating Straddle

This tool is designed when pressure and deflection are a problem. The knurling heads are able to "float" somewhat and center on the workpiece, compensating for any off-centering. Precise square shank with preset center height. A diametrical adjustment screw regulates the depth of the knurl pattern and diameter size. Refer to the CNC-DN7 when tool clearance is a problem.

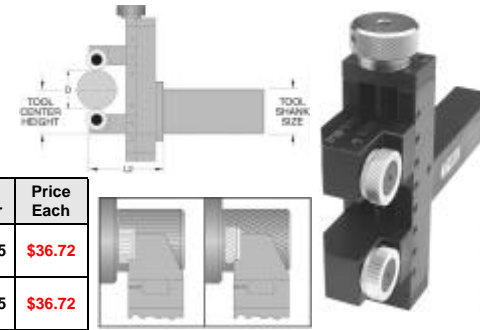

Center Height	Shank Size	Max.	L2	Description	Part Number	Price Each	Knurl Wheel	Knurl Pin Set	Part Number	Price Each
0.750	.750x1.00	2	3.125	KTW109-75-2-4	DN22810	\$352.98	SW4R/L-25C	SW4.0P-2S	DN29085	\$36.72
1.000	1.00x1.00	2	3.125	KTW109-100-2-4	DN22820	\$366.76				
1.000	1.00x1.25	3	4.25	KTW109-100-3-4	DN22830	\$474.88	SW4R/L-25C	SW4.0P-2S	DN29085	\$36.72
1.250	1.25x1.25	3	4.25	KTW109-125-3-4	DN22840	\$474.88				

## KT109-00D - Diametral Knurling Tool for Manual or CNC Lathes

Designed to knurl small diameter parts. Precision round shank has an I.D. bore allowing small diameter material to pass through. Two knurl wheels are held in a cartridge that can be rotated allowing for one set of straight knurl wheels to be used for knurling a diamond or straight pattern. Knurl wheels are mounted between thrust washers to ensure smooth and even rotation of the knurl while knurling is performed.

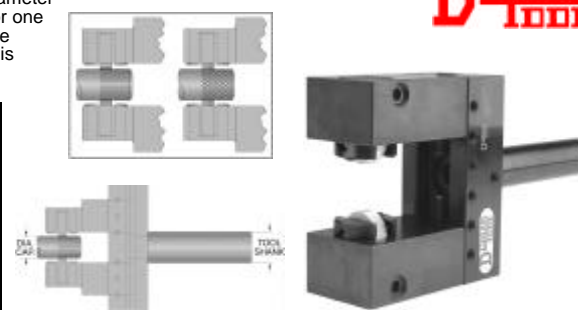

Shank Size	Cap.	Description	Part Number	Price Each	Knurl Wheel	Knurl Pin Set	Part Number	Price Each
0.750	1	KT109-100-75D-R	DN22710	\$514.10	RS-25-C	KPS-25-75	DN28820	\$6.89
1.000	1.5	KT109-150-100D-R	DN22720	\$571.34				
1.250	2	KT109-200-125D-R	DN22730	\$594.66				
0.750	3	KT109-300-75D-M	DN22740	\$723.98	MS-25-C	KPS-31-125	DN28850	\$7.53
1.000	3	KT109-300-100D-M	DN22750	\$723.98				
1.250	3	KT109-300-125D-M	DN22760	\$723.98				

Supplied with two 25 TPI knurl wheels for straight or diamond pattern

## 3WKT - Three Wheel Knurling Tool for Manual or CNC Lathe

Designed for knurling small diameter parts. Great for small diameters, long lengths, and tubing. Three knurl wheels surround the part offering support to minimize deflection. The knurl wheels are mounted on thrust washers to ensure a smooth and even rotation of the knurls while knurling is performed. Optional round shank has an I.D. bore so that the smaller part can ride through the shank.

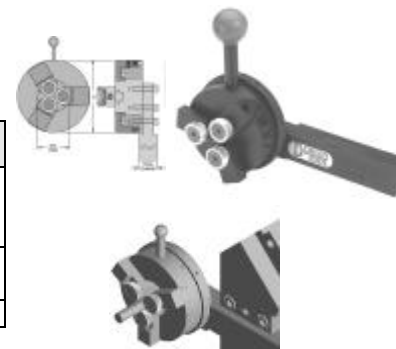

Center Height	Shank Size	Cap.	D	Description	Part Number	Price Each	Knurl Wheel	Knurl Pin Set	Part Number	Price Each
0.500	.500x.500	.080-.25	1.75	3WKT-06-50-2	DN23010	\$973.08	SW2-S/R/L	SW2.0P-3S	DN29060	\$46.98
0.625	.625x.625	.080-.50	2.25	3WKT-12-162-2	DN23015	\$1,016.33				
0.750	.750x.750	.125-1.0	3.00	3WKT-25-75-2	DN23030	\$1,074.84	SW3.5-S/R/L	SW3.5P-3S	DN29075	\$51.84
1.000	1.00x1.00	.187-1.5	4.25	3WKT-40-100-3	DN23040	\$1,601.45				
1.000	1.00x1.00	.375-2.5	5.25	3WKT-65-100-3	DN23050	\$1,864.75				
1.000	1.00x1.00	.500-3.5	6.25	3WKT-90-100-4	DN23060	\$2,435.88	SW4-S/R/L	SW4.0P-3S	DN29090	\$55.08

Supplied with three 30 or 25 TPI knurl wheels for diamond pattern

Call Us Or Visit Our Website For Our Complete Selection!

# KNURLING WHEELS



## "SW3.5" Series Cobalt

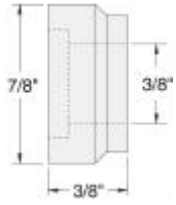

- "SW" knurling wheels are technically designed to knurl against a square shoulder.
- With super precise workmanship, the wheels are made of heat treated High Cobalt Steel to withstand severe knurling operation.
- Knurl wheels are Titanium Nitriding coated to reduce the co-efficient of friction when knurling, increasing the quality and the force of knurling as well as the life of the knurl wheels.
- All SW Series knurl wheels are available only in cobalt and tin coated.

TPI	Incl. Tooth Angle	PATTERN		
		Straight	Diagonal Right	Diagonal Left
14	90°	DN27702	DN27756	DN27810
16	90°	DN27704	DN27758	DN27812
20	90°	DN27706	DN27760	DN27814
25	90°	DN27708	DN27762	DN27816
30	90°	DN27710	DN27764	DN27818
35	90°	DN27712	DN27766	DN27820
40	90°	DN27714	DN27768	DN27822
50	70°	DN27716	DN27770	DN27824
Price Each		\$45.36	\$45.36	\$45.36

## "SW2" Series

Cobalt

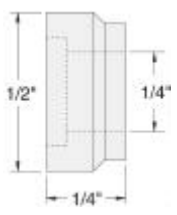

TPI	Incl. Tooth Angle	PATTERN		
		Straight	Diagonal Right	Diagonal Left
16	90°	DN27402	DN27452	DN27502
20	90°	DN27404	DN27454	DN27504
25	90°	DN27406	DN27456	DN27506
30	90°	DN27408	DN27458	DN27508
35	90°	DN27410	DN27460	DN27510
40	90°	DN27412	DN27462	DN27512
50	70°	DN27414	DN27464	DN27514
Price Each		\$38.88	\$38.88	\$38.88

## "SW4" Series Cobalt

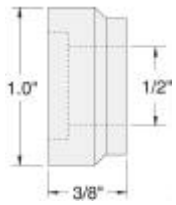

TPI	Incl. Tooth Angle	PATTERN		
		Straight	Diagonal Right	Diagonal Left
14	90°	DN28002	DN28056	DN28110
16	90°	DN28004	DN28058	DN28112
20	90°	DN28006	DN28060	DN28114
25	90°	DN28008	DN28062	DN28116
30	90°	DN28010	DN28064	DN28118
35	90°	DN28012	DN28066	DN28120
40	90°	DN28014	DN28068	DN28122
50	70°	DN28016	DN28070	DN28124
Price Each		\$49.68	\$49.68	\$49.68



## CIRCULAR PITCH KNURLS

Made to extremely high standards from the finest materials available. Knurls are individually hob cut and lapped to a smooth hard finish to give longer life and impart a smooth clean surface to the knurled part. Knurls available in High Speed, Cobalt, TIC/N - Coated, beveled, and diametral pitch.



## "A" Series

High Speed Steel

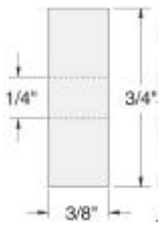

TPI	Incl. Tooth Angle	PATTERN		
		Straight	Diagonal Right	Diagonal Left
10	90°	DN23502	DN23634	DN23766
12	90°	DN23504	DN23636	DN23768
14	90°	DN23506	DN23638	DN23770
16	90°	DN23508	DN23640	DN23772
20	90°	DN23510	DN23642	DN23774
25	90°	DN23512	DN23644	DN23776
30	90°	DN23514	DN23646	DN23778
35	90°	DN23516	DN23648	DN23780
40	90°	DN23518	DN23650	DN23782
50	70°	DN23520	DN23652	DN23784
80	70°	DN23522	DN23654	DN23786
Price Each		\$14.04	\$25.38	\$15.66

## "C" Series

High Speed Steel

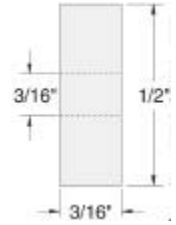

TPI	Incl. Tooth Angle	PATTERN		
		Straight	Diagonal Right	Diagonal Left
16	90°	DN24502	DN24610	DN24718
20	90°	DN24504	DN24612	DN24720
25	90°	DN24506	DN24614	DN24722
30	90°	DN24508	DN24616	DN24724
35	90°	DN24510	DN24618	DN24726
40	90°	DN24512	DN24620	DN24728
50	70°	DN24514	DN24622	DN24730
80	70°	DN24516	DN24624	DN24732
Price Each		\$11.88	\$12.96	\$12.96

## "R" Series

Cobalt

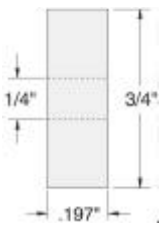

TPI	Incl. Tooth Angle	PATTERN		
		Straight	Diagonal Right	Diagonal Left
10	90°	DN26502	DN26564	DN26626
12	90°	DN26504	DN26566	DN26628
14	90°	DN26506	DN26568	DN26630
16	90°	DN26508	DN26570	DN26632
20	90°	DN26510	DN26572	DN26634
25	90°	DN26512	DN26574	DN26636
30	90°	DN26514	DN26576	DN26638
35	90°	DN26516	DN26578	DN26640
40	90°	DN26518	DN26580	DN26642
50	70°	DN26520	DN26582	DN26644
Price Each		\$26.46	\$26.46	\$26.46

## "D" Series

Cobalt

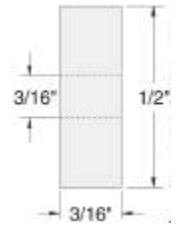

TPI	Incl. Tooth Angle	PATTERN		
		Straight	Diagonal Right	Diagonal Left
16	90°	DN25002	DN25056	DN25110
20	90°	DN25004	DN25058	DN25112
25	90°	DN25006	DN25060	DN25114
30	90°	DN25008	DN25062	DN25116
35	90°	DN25010	DN25064	DN25118
40	90°	DN25012	DN25066	DN25120
50	70°	DN25014	DN25068	DN25122
80	70°	DN25016	DN25070	DN25124
Price Each		\$23.76	\$23.76	\$23.76

## "O" Series

High Speed Steel

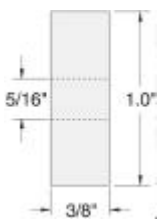

TPI	Incl. Tooth Angle	PATTERN		
		Straight	Male Diamond	Female Diamond
12	90°	DN25606	—	—
14	90°	DN25608	—	—
16	90°	DN25610	—	—
20	90°	DN25612	DN26008	DN26074
25	90°	DN25614	DN26010	DN26076
30	90°	DN25616	DN26012	DN26078
Price Each		\$19.44	\$30.24	\$30.24

## "S" Series

High Speed Steel

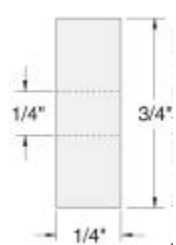

TPI	Incl. Tooth Angle	PATTERN		
		Straight	Diagonal Right	Diagonal Left
10	90°	DN26802	DN26924	DN27048
12	90°	DN26804	DN26926	DN27050
14	90°	DN26806	DN26928	DN27052
16	90°	DN26808	DN26930	DN27054
20	90°	DN26810	DN26932	DN27056
25	90°	DN26812	DN26934	DN27058
30	90°	DN26814	DN26936	DN27060
35	90°	DN26816	DN26938	DN27062
40	90°	DN26818	DN26940	DN27064
50	70°	DN26820	DN26942	DN27066
Price Each		\$13.50	\$14.04	\$14.04

Call Us Today For All Of Your Machine Tool Needs!