

SPECIAL ORDER JAW FORMS

Metric & Imperial Serrations

Customer #: _____ Date: _____

Company Name: _____ Your Name: _____

Address: _____

Phone: _____ FAX: _____

PLEASE NOTE: Special Order jaws are NON-REFUNDABLE. Special Order Soft Jaws have a 3 set (9 piece) minimum. Special Order Round Jaws have no minimum.

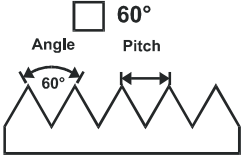
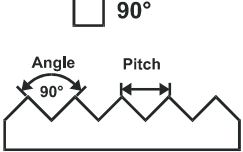
Angle of Tooth	Pitch	Style of Jaw you Need	Number of Holes
<input type="checkbox"/> 60° 	<input type="checkbox"/> 1.5 mm (.059")	1.5 mm X 60° Serrations	2 Holes Only
	<input type="checkbox"/> 3.0 mm (.118")	3.0 mm X 60° Serrations	
<input type="checkbox"/> 90° 	<input type="checkbox"/> 1/16 inch	1/16" X 90° Serrations	<input type="checkbox"/> 2 Holes
	<input type="checkbox"/> 3/32 inch	3/32" X 90° Serrations Pages: 24 - 25	<input type="checkbox"/> 3 Holes

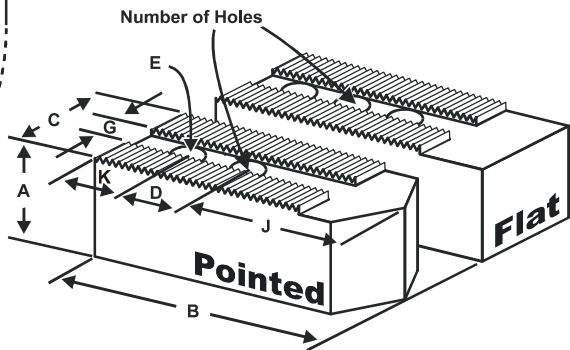
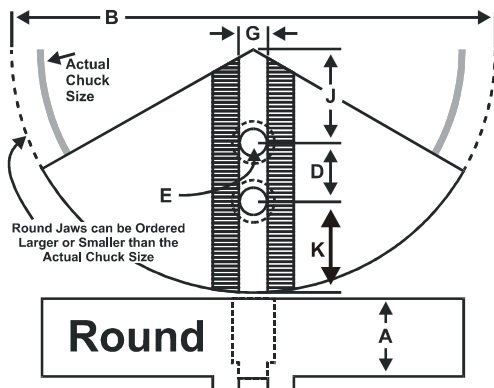

Style of Jaw: _____ Quantity (in sets of 3) : _____

Actual Chuck Size	Critical Dimensions			Dimensions			Material & Style		
	G Groove Width	E Screw Size	D Hole Space	J Hole to Front	C Width Inch	B Length or Dia.	A Height Inch	Steel Aluminum or Cast Iron	Flat or Pointed or Round

Chuck Make & Model Number _____

Chuck make and model number may help us provide better service to you.

PLEASE FILL OUT IF PLACING AN ORDER:

PO#: _____ Customer Signature: _____ Date: _____

OFFICE USE ONLY

Quoted By: _____

List Price per Set: _____ (Valid for 30 Days) Job#: _____

Order Will Ship _____ days after receipt of order (i.e. PO#) Quote#: _____

Call Us Or Visit Our Website For Our Complete Selection!

SPECIAL ORDER JAW FORMS

Tongue & Groove Style

Customer #: _____

Date: _____

Company Name: _____

Your Name: _____

Address: _____

Phone: _____

FAX: _____

PLEASE NOTE: Special Order jaws are NON-REFUNDABLE. Special Order Soft Jaws have a 3 set (9 piece) minimum. Special Order Round Jaws have no minimum.

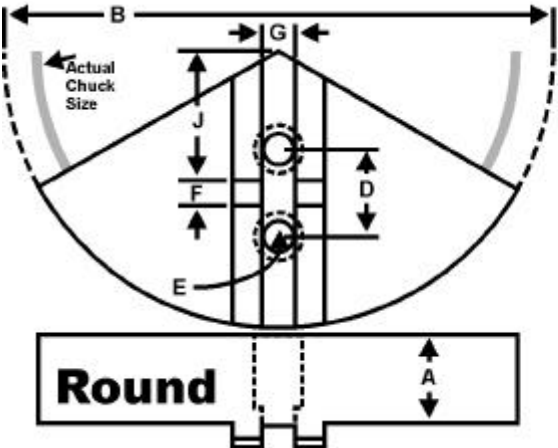

Round Jaws can be ordered Larger or Smaller than the Actual Chuck Size

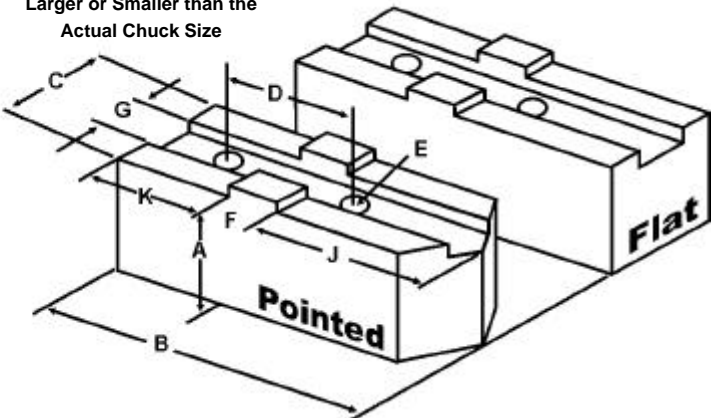

Screw Size: 5/16, 3/8, 7/16, 1/2, 5/8, 3/4

Style of Jaw: _____ Quantity (in sets of 3) : _____

Critical Dimensions				Dimensions					Material & Style	
Actual Chuck Size	G Groove Width	E Screw Size	D Hole Space	F Tongue Width	J Hole to Front	C Width Inch	B Length or Dia.	A Height Inch	Steel Aluminum or Cast Iron	Flat or Pointed or Round

Chuck Make & Model Number _____

Chuck make and model number may help us provide better service to you.

PLEASE FILL OUT IF PLACING AN ORDER:

PO#: _____ Customer Signature: _____ Date: _____

OFFICE USE ONLY	Quoted By: _____
List Price per Set: _____ (Valid for 30 Days)	Job#: _____
Order Will Ship _____ days after receipt of order (i.e. PO#)	Quote#: _____

Call Us Today For All Of Your Machine Tool Needs!

SPECIAL ORDER JAW FORMS

Square Serrated Style

Customer #: _____

Date: _____

Company Name: _____ Your Name: _____

Address: _____

Phone: _____ FAX: _____

PLEASE NOTE: Special Order jaws are NON-REFUNDABLE. Special Order Soft Jaws have a 3 set (9 piece) minimum. Special Order Round Jaws have no minimum.

Screw Sizes:

- 5/16
- 3/8
- 1/2
- 5/8
- 3/4

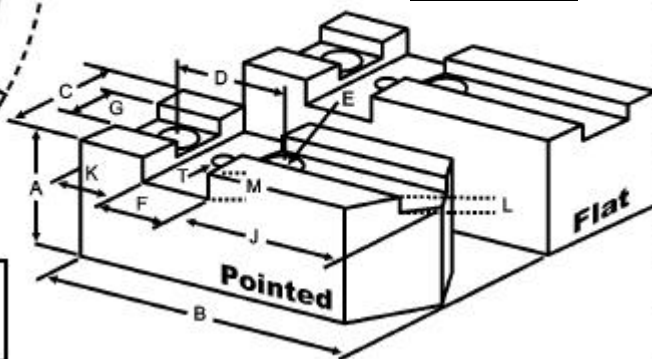
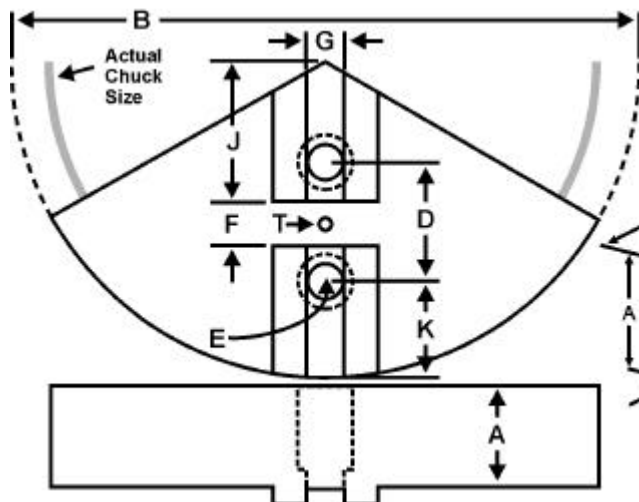

Style of Jaw: _____ Quantity (in sets of 3) : _____

Critical Dimensions							Dimensions					Material & Style	
Actual Chuck Size	G Groove Width	M Groove Depth	E Screw Size	F Key Width	L Key Depth	D Hole Space	J Key to Front	T Thread Size	C Width Inch	B Length or Dia.	A Height Inch	Steel Aluminum or Cast Iron	Flat or Pointed or Round

Chuck Make & Model Number _____

Chuck make and model number may help us provide better service to you.

PLEASE FILL OUT IF PLACING AN ORDER:

PO#: _____ Customer Signature: _____ Date: _____

OFFICE USE ONLY	Quoted By: _____
List Price per Set: _____ (Valid for 30 Days)	Job#: _____
Order Will Ship _____ days after receipt of order (i.e. PO#)	Quote#: _____

Call Us Or Visit Our Website For Our Complete Selection!

SPECIAL ORDER JAW FORMS

Acme Serrated Style

Customer #: _____

Date: _____

Company Name: _____

Your Name: _____

Address: _____

Phone: _____

FAX: _____

PLEASE NOTE: Special Order jaws are NON-REFUNDABLE. Special Order Soft Jaws have a 3 set (9 piece) minimum. Special Order Round Jaws have no minimum.

Screw Sizes:
 1/2
 5/8
 3/4
 7/8

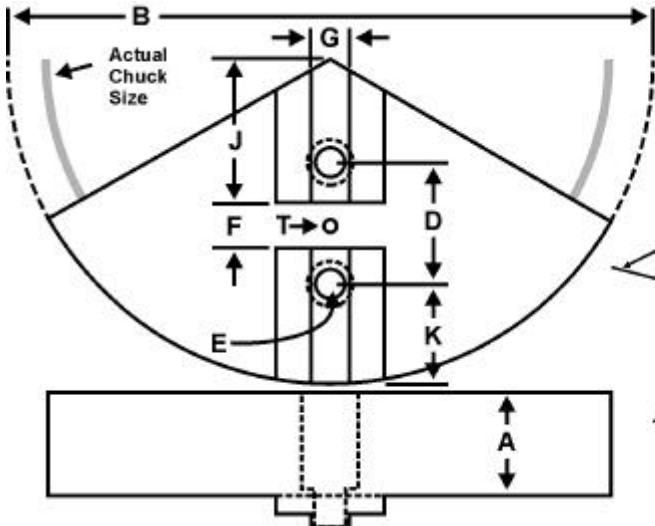

Round Jaws can be ordered Larger or Smaller than the Actual Chuck Size

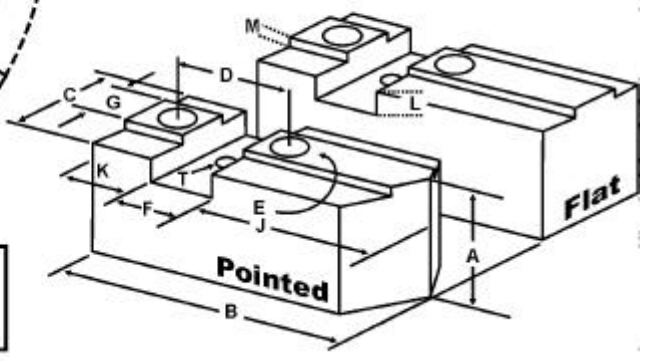

Style of Jaw: _____

Quantity (in sets of 3) : _____

Actual Chuck Size	Critical Dimensions						Dimensions					Material & Style	
	G Tongue Width	M Tongue Depth	E Screw Size	F Key Width	L Key Depth	D Hole Space	J Key to Front	T Thread Size	C Width Inch	B Length or Dia.	A Height Inch	Steel Aluminum or Cast Iron	Flat or Pointed or Round

Chuck Make & Model Number _____

Chuck make and model number may help us provide better service to you.

PLEASE FILL OUT IF PLACING AN ORDER:

PO#: _____ Customer Signature: _____ Date: _____

OFFICE USE ONLY	Quoted By: _____
List Price per Set: _____	(Valid for 30 Days) Job#: _____
Order Will Ship _____ days after receipt of order (i.e. PO#)	Quote#: _____

Call Us Today For All Of Your Machine Tool Needs!

SPECIAL ORDER JAW FORMS

For Northfield™ Style Chucks

Customer #: _____

Date: _____

Company Name: _____

Your Name: _____

Address: _____

Phone: _____ FAX: _____

PLEASE NOTE: Special Order jaws are NON-REFUNDABLE. Special Order Soft Jaws have a 3 set (9 piece) minimum. Special Order Round Jaws have no minimum.

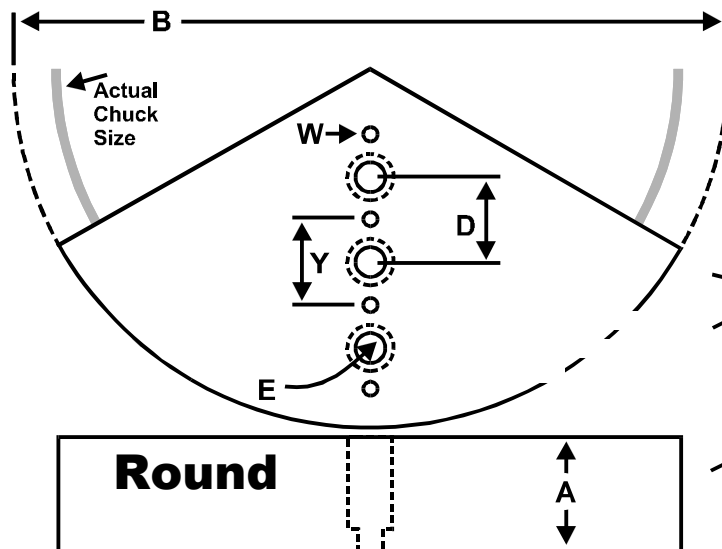

Round Jaws can be ordered Larger or Smaller than the Actual Chuck Size
Northfield is a trademark of Northfield Precision Instrument Corp.

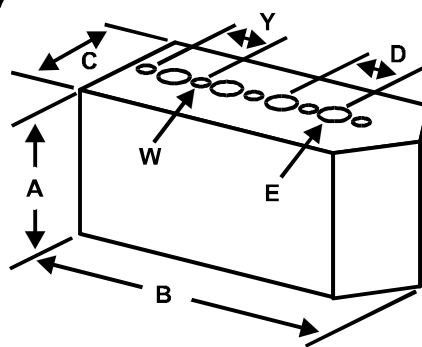

Style of Jaw: _____ Quantity (in sets of 3) : _____

Actual Chuck Size	No. Of Pin Holes	No. Of Screw Holes	Critical Dimensions				Dimensions			Material & Style		
			W Pin Hole Size	Y Pin Space	E Screw Size	D Hole Space	C Width Inch	B Length or Dia.	A Height Inch	Steel or Aluminum	Pointed or Round	

Chuck Make & Model Number _____

Chuck make and model number may help us provide better service to you.

PLEASE FILL OUT IF PLACING AN ORDER:

PO#: _____ Customer Signature: _____ Date: _____

OFFICE USE ONLY	Quoted By: _____
List Price per Set: _____ (Valid for 30 Days)	Job#: _____
Order Will Ship _____ days after receipt of order (i.e. PO#)	Quote#: _____

Call Us Or Visit Our Website For Our Complete Selection!