

POWER CHUCKS

N-200 A SERIES CHUCKS-3 JAW

1.5mm x 60° Serrations Power Chucks

Strong produces high quality chucks that are interchangeable with Kitagawa™ B200 series chucks. These popular power chucks are also available in 2, 4 and 6 jaw models.

Chucks Are Interchangeable With Kitagawa™ B200 Series Chucks!



Full Line Available!
Please call for more information.

Chucks Includes:
1.5mm x 60° Master Jaws
Blank Drawnut • Soft Top Jaws
T-Nuts • Mounting Bolts • Wrench

FEATURES:

- Approx. 20% higher speed, higher gripping force and larger bore compared with usual chucks.
- Model N-200A chucks are assembled with adapter for ASA B5.9 type A spindles.
- Model N-200A chucks are manufactured from high grade alloy steel. All sliding surfaces are hardened and ground for accurate actual running and long service repeatability.

Chuck Size	Chuck Dia.	Thru-hole Dia.	Mount	Part Number	Price Each
5"	5.315"	1.299"	A2-4	UT-N205A4	\$1,782.00
			A2-5	UT-N205A5	
6"	6.654"	1.772"	A2-4	UT-N206A4	\$1,962.00
			A2-5	UT-N206A5	
8"	8.268"	2.047"	A2-5	UT-N208A5	\$2,232.00
			A2-6	UT-N208A6	
10"	10.000"	2.953"	A2-6	UT-N210A6	\$2,682.00
			A2-8	UT-N210A8	
12"	11.969"	3.585"	A2-6	UT-N212A6	\$3,582.00
			A2-8	UT-N212A8	
15"	15.000"	4.626"	A2-8	UT-N215A8	\$4,842.00
			A2-11	UT-N215A11	
18"	17.717"	4.626"	A2-8	UT-N218A8	\$7,092.00
			A2-11	UT-N218A11	

REMEMBER!
For optimum performance, it is recommended that you grease your chuck once per shift.

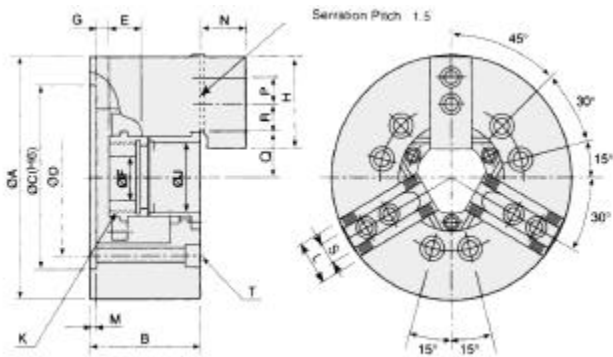

Specifications	N205	N206	N208	N210	N212	N215	N218
Through-Hole (mm)	Ø33	Ø45	Ø52	Ø75	Ø91	Ø117.5	Ø117.5
Plunger Stroke (mm)	10	12	16	19	23	23	23
Jaw Stroke (mm)	5.4	5.5	7.4	8.8	10.6	10.6	10.6
Max. Draw Bar Pull Force (kgf)	1700	2200	3400	4300	5500	7240	7240
Max. Gripping Force (kgf)	3600	5700	8800	11000	14300	18355	18355
kgf/cm2	29.6	28.5	26.5	27.5	27.5	23.5	23.5
Max. Speed (r.p.m.)	7000	6000	4900	4200	3300	2500	2000

NT-200 SERIES CHUCKS-2 JAW

1.5mm x 60° Serrations Power Chucks



Full Line Available!
Please call for more information.

Chucks Includes:
1.5mm x 60° Master Jaws
Blank Drawnut • Soft Top Jaws
T-Nuts • Mounting Bolts • Wrench

Chuck Size	Chuck Dia.	Thru-hole Dia.	Mount	Part Number	Price Each
5"	5.315"	1.299"	A2-4	UT-NT205A4	\$1,962.00
			A2-5	UT-NT205A5	
6"	6.654"	1.772"	A2-4	UT-NT206A4	\$2,142.00
			A2-5	UT-NT206A5	
8"	8.268"	2.047"	A2-5	UT-NT208A5	\$2,592.00
			A2-6	UT-NT208A6	
10"	10.000"	2.953"	A2-6	UT-NT210A6	\$3,222.00
			A2-8	UT-NT210A8	
12"	11.969"	3.585"	A2-6	UT-NT212A6	\$4,122.00
			A2-8	UT-NT212A8	

NIT-200 SERIES CHUCKS-4 JAW

1.5mm x 60° Serrations Power Chucks



Full Line Available!
Please call for more information.

Chucks Includes:
1.5mm x 60° Master Jaws
Blank Drawnut • Soft Top Jaws
T-Nuts • Mounting Bolts • Wrench

Chuck Size	Chuck Dia.	Thru-hole Dia.	Mount	Part Number	Price Each
8"	8.268"	2.047"	A2-5	UT-NIT208A5	\$3,222.00
			A2-6	UT-NIT208A6	
10"	10.000"	2.953"	A2-6	UT-NIT210A6	\$3,852.00
			A2-8	UT-NIT210A8	
12"	11.969"	3.585"	A2-6	UT-NIT212A6	\$4,980.00
			A2-8	UT-NIT212A8	

Call Us Today For All Of Your Machine Tool Needs!