

CHICK SYSTEM 5

**CA, AZ, NV CUSTOMERS-
SAVE LEAD TIME!**

Call us and let us know which CHICK jaws you need so that we may stock them for you in California to help save you valuable time!

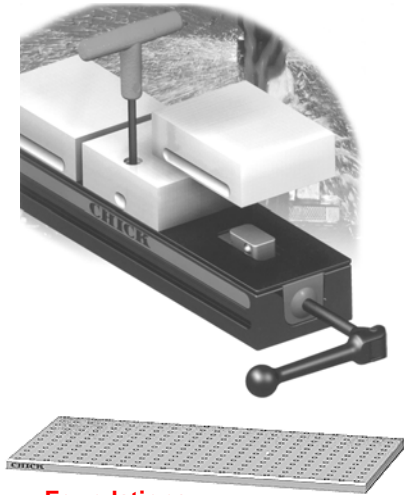

Foundations

Machinable Jaws

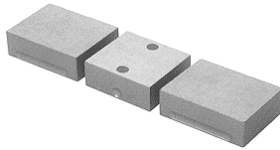

Machinable Faceplates

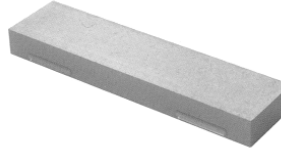

CNC Vise



**Multi-Lock
Workholding Systems**

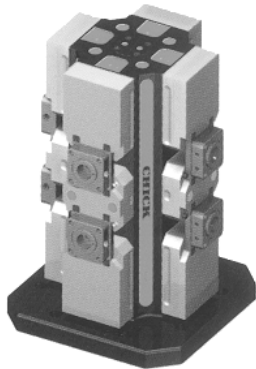

**Qwik-Lok & Bi-Lok
Workholding Systems**

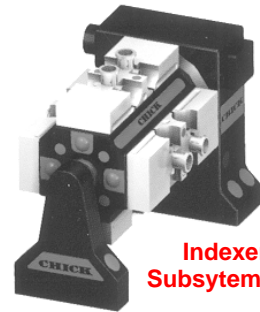
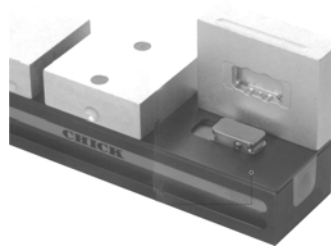

**Indexer
Subsystems**

TOOLEX VISE SYSTEMS

The Toolex® ReLock Vise System combines high manufactured tolerances with excellent versatility in providing two-station and eight-station production vises. These CNC vises, available with machinable soft jaws, hard jaws, master jaws and parallels, or fixture plates, allow a machinist several different configurations with the same vise. Bodies are manufactured from 80,000 PSI ductile cast iron, ways are flame hardened and ground to accuracies of +/- .0005. Manual and hydraulic two-station and eight-station vises are available in widths of 4", 6" and 8."

WISE SYSTEMS

- MANUAL & HYDRAULIC VISES •
- SNAPLOCK™ JAWS & FIXTURE PLATES •
- ACCUSNAP™ JAWS & PARALLELS •
- QUICKCHANGE™ JAWS & PARALLELS •

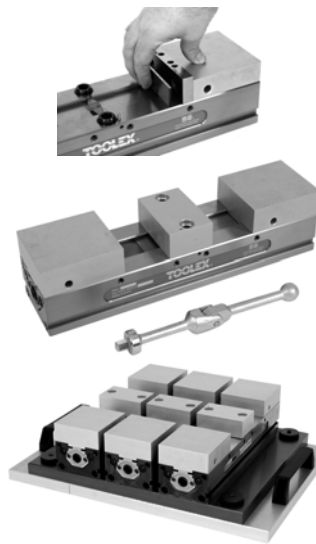

Full Line Available!
Please call for more information.

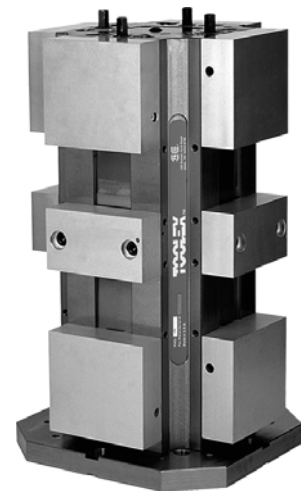

PARLEC WORKHOLDING SYSTEMS

The Parlec Workholding System has been designed to take full advantage of the advancements in computerized numerically controlled milling machines. We can maximize your machine's work envelope, increasing productivity by presenting more work pieces to the spindle. Reduced cycle time is also achieved, decreasing the cost per part. This system offers accurate relocation for repeat jobs, minimizing set-up times from project to project, eliminating the need for dedicated fixturing. Machinist can walk away to run other machines due to the increased spindle time.

**PLEASE CALL FOR
MORE INFORMATION!**

- Tombstones •
- Vises •
- Replacement Jaws •



LATHE CHUCKS
LIVE CENTERS

VISE JAWS
VISE ACCESSORIES

STRAIGHT SHANK
COLLET HOLDERS

LATHE BUSHINGS
DRILL CHUCKS

CARBIDE INSERTS
THREADING/GROOVING

CUTTING TOOLS
MACHINERY

PRECISION TOOLS
DEBURRING

COOLANT/FLUIDS
TOOL STORAGE

Call Us Or Visit Our Website For Our Complete Selection!