

VICES/VICE ACCESSORIES

VISE KEYS

Hardened

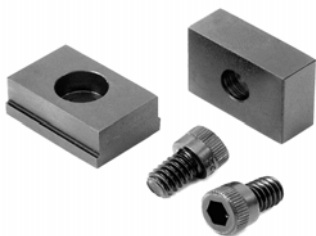

Vise Size	Key Size	Part Number
5-6"	11/16x5/8"	KURT-D50-33A
	11/16x13/16"	KURT-D50-33B
	11/16x3/4"	KURT-D50-33C
	11/16x9/16"	KURT-D50-33D
	11/16x1/2"	KURT-D50-33E
Square Keys (set of 2)		
5-6"	11/16x11/16	KURT-D50-50

\$35.00 per pair

HEX EXTENSIONS

Hex Extensions are useful when the vises are mounted on large machines where extending the hex will allow better access. Hex extensions will also allow a 6" handle to be used on a 4" or 8" vise.



Vise Size	Part Number	Price Each
4" to 6"	KURT-HEX4A6	\$129.00
4" to 4"	KURT-HEX4	\$20.00
6" to 6"	KURT-HEX6	\$48.00
8" to 6"	KURT-HEX8A6	\$88.00

SELF ALIGNING CLAMPS

Set of 4



Vise Size	Part Number	Price
5-6" Vises	KURT-D50-46	\$120.65

KURT GREASE

FEATURES:

- Goes with you everywhere!
- Fits standard grease fittings
- Easy, one hand operation
- NLGI #2 grease is specifically formulated to prevent water wash out
- Includes Universal nozzle and spring-loaded pump for application on KURT vises and workholding products



Part Number	Price Each
KURT-KLA	\$17.00



KURT KOOLANT SHIELD

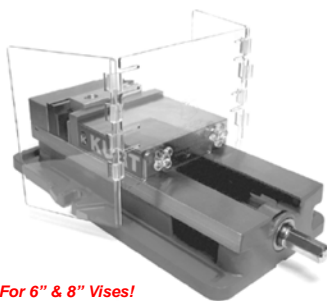

FEATURES:

- Transparent so the operator can see the workpiece easily
- Keeps coolant within a confined area to avoid coolant waste and ease cleanup
- Sides adjust from 0 to 230° to accommodate tight setups.
- Made from durable polycarbonate for high strength and rigidity.

Part Number	Price Each
KURT-KKS	\$42.00

For 6" & 8" Vises!

COOLANT SHIELD



Helps to protect machine operators from coolant spray and chips. It mounts quickly and easily onto the vise jaw and is easily movable when access to the workpiece is desired.

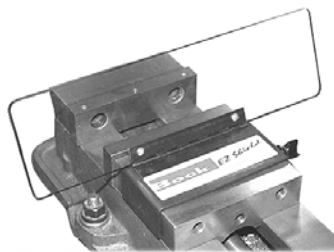

Vise Size	Part Number	Price Each
4"	BOCK-EZ-STD03	\$49.00
6"	BOCK-EZ-STD01	\$49.00
8"	BOCK-EZ-STD02	\$59.00

EZ-TRAM MILL ALIGNMENT TOOL

EZ-TRAM allows the machinist to quickly and accurately check and align the spindle of a vertical turret mill, perpendicular to the machine table without disturbing the work set-up. This feature reduces inaccuracies due to sag in the saddle and knee while eliminating the need to remove the vise. All EZ-TRAMs are a one piece casting of silicon manganese iron and are precision lapped flat to within .000070" over the entire gaging surface and parallel to within .00030" surface to surface. They are shipped in a heavy duty cardboard container with a custom built insert designed to support the tool. All EZ-TRAM products are cast and machined in U.S.A. and come with a 30 day money back guarantee and a LIFETIME WARRANTY.



FEATURES:

- One piece casting
- Precision lapped flat to within .000070"
- Parallel to within .00030" surface to surface

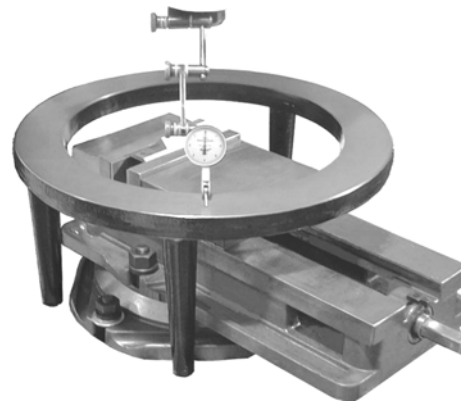

EZ-TRAM-15.8" diameter with a 1.8" wide gaging surface, fits over a 6" machine vise with swivel base. Designed to fit on milling machines with 9" wide or larger tables.

MINI-TRAM-13" diameter with a 1.75" gaging surface and will fit over a 6" machine vise without a swivel base. Designed to fit on milling machines with 8" wide or larger tables.

MICRO-TRAM-10" diameter with a 1.6" wide gaging surface and will fit over a 4" machine vise. Designed to fit on milling machines with 6" wide or larger tables.

Description	Dia	Gaging Surface	Weight	Part Number	Price Each
Micro-Tram	10"	1.6"	15 lbs	TRAM-MICRO	\$126.42
Mini-Tram	13"	1.75"	22 lbs	TRAM-MINI	\$175.42
EZ-Tram	15.8"	1.8"	32 lbs	TRAM-EZ	\$249.00

Call Us Today For All Of Your Machine Tool Needs!

CARPAL CUSHION™

Machine Vise Handle Grip

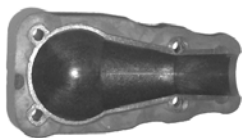

- Quickly mounts on machine vise handle-tapered and ball end
- Cushions impact between hand and handle, reducing the risk of hand injury
- Includes mounting hardware

Designed to quickly mount on a milling machine vise handle with 4 screws, the unique design fits both tapered and ball end handles. The ergonomic Santoprene CARPAL CUSHION™ grips reduce the risk of hand injury by cushioning the impact between the machinist's hand and the vise handle. The soft cushion grip also protects the milling machine components such as cross feed handles and table surfaces that the vise handle can strike.

Description	Part Number	Price Each
Machine Vise Handle Grip	GM-CC-2000	\$19.95

C

SPEED GUARD HANDLE PROTECTOR



Prolong the life of your speed handle! The Speed Guard evenly distributes torque among the three arms of your handle, reinforcing your handle for added strength and support.

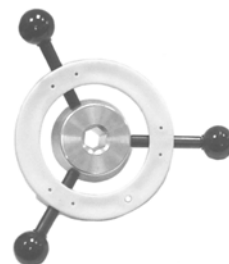

No More Broken Handles!

- Prolongs handle life-evenly distributes torque
- For machine vise and drill press handles or any 3 prong handle that needs support!
- Quick and easy to install
- High visibility safety yellow
- Includes all hardware

Description	Part Number	Price
Speed Guard	PMC-GUARD	\$5.99
Speed Guard w/ Handle	PMC-SPEED-KIT	\$36.56

D

KURT SPEED HANDLE

Spend less time clamping and get a handle on your next job. The Kurt Speed Handles fit the 4" and 6" AngLock vises and opens completely in seconds. It doesn't interfere with the milling machine, giving you rapid part loading and unloading.



Vise Size	Part Number	Price Each
4"	KURT-D40SH	\$95.00
6"	KURT-D60SH	\$132.00

SPEED HANDLE

For milling machine vises.

FEATURES:

- Fits 6" Kurt Anglock Vises
- Vises can be completely opened in a few seconds
- Save time & increase production
- 3/4" Hex Hole



BEST VALUE



Hex Size	Part Number	Price Each
3/4"	US-SPEED-6	\$31.05

TORQUE HANDLE

The torque handle has all the benefits of the Speed Handle, yet provides calibration guides for your torquing requirements. Used on 6" vises like the Speed Handle, it doesn't interfere with your milling machines and is made of durable steel, not aluminum, so your hex nut won't strip.



KURT TH6 Torque vs. Position				
Position	1	2	3	4
Torque	6	8	10	20

Description	Part Number	Price Each
Torque Handle	KURT-TH-6	\$239.00

ARMLOCK® HANDLE



Fits 6" Vises!



This adjustable lever length handle is designed to allow spinning of the vise screw with the lever in the central position for fast jaw movement and light work clamping. Comfortable, higher torque clamping is possible when lever is in #2 position. By adding an adapter the handle can be used on 4" or 8" vises.

Description	Part Number	Price Each
6" Armlock Handle	KURT-AL6	\$79.00

SOFT TOUCH SPEED HANDLE

The Soft Touch Speed Handle works just like the handle you are using now, except that it will not clamp as tight on parts. Excellent for all types of plastic and thin-walled parts, as well as parts requiring critical surface finishes. Fits most 6" vises



Made of Aircraft Grade 6061-T65 aluminum. Gold hard anodized for wear protection.

Lightly Clamp On Thin Parts!

Description	Part Number	Price Each
Soft Touch Speed Handle	THA-STSH	\$29.99

THE PLANK™



For 5/8" T-slots!

Move Your Vise Safely & Easily!

Supports the weight of heavy vises, rotary tables, fixtures and work pieces, allowing the machine operator to safely load and unload heavy items onto the table of the machine!

- Eliminate the need for the machine operator to lift heavy objects.
- Minimizes injury or strain to operators.
- Securely attaches to machine tool tables in seconds.
- Made from 356 T6 Aluminum.

The Plank Vise Support
Part # PLANK-625
\$99.00

Call Us Or Visit Our Website For Our Complete Selection!

LATHE CHUCKS
LIVE CENTERS

WISE ACCESSORIES
VISE JAWS

STRAIGHT SHANK
COLLET HOLDERS

LATHE BUSHINGS
DRILL CHUCKS

CARBIDE INSERTS
THREADING/GROOVING

CUTTING TOOLS
MACHINERY

PRECISION TOOLS
DEBURRING

COOLANT/FLUIDS
TOOL STORAGE

WISE ACCESSORIES

ANGLOCK® VISE WORK STOPS

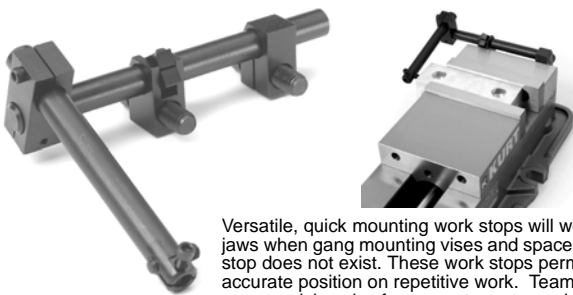

Versatile, quick mounting work stops will work above jaws when gang mounting vises and space for a work stop does not exist. These work stops permit fast, accurate position on repetitive work. Teams up with your precision vise for accurate parts production.

Vise Model	Part Number	Price Each
3-4" Vises	KURT-D30-45	\$110.00
5-6" Vises	KURT-360PWS	\$138.00
8" Vises	KURT-D80WS	\$143.00

KURT GROOVE LOCK WORKSTOP

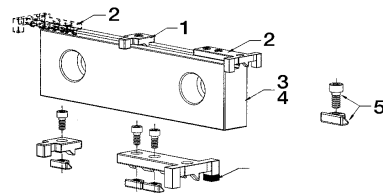

- Does not interfere with parts or spindle
- Single bolt design used for tightening workstop

See Fig.	Description	Part Number	Price Each
1	Workstop assembly suitable for 2-6" jaw plates	KURT-WSRL46	\$16.00
2	Extended length workstop assembly suitable to use with 4-6" jaw on outside.	KURT-WSRLE46	\$24.00
3	6" GrooveLock Jawplate (not reversible)	KURT-D60-315	\$38.00
4	4" GrooveLock Jawplate (not reversible)	KURT-D40-315	\$39.00
5	Replacement Clamp Assembly	KURT-WSRL4686SA	\$10.00

SWING-STOP WORKSTOP



For easy & accurate repeat set-ups!



Description	Part Number	Price
Single Station	BOCK-PW-STD01	\$99.00
Dual Station	BOCK-PW-STD02	\$189.00

WORKSTOP



FEATURES:

- Body clamp has 2" adjustment
- 3" long stop pin for fast set-ups
- Versatile and economical!
- Black oxide finish
- Fast accurate positioning of parts
- Short & long spacers available

Description	Part Number	Price Each
Workstop	KURT-6AWS	\$62.00
Short Spacer	KURT-6AWS-288	\$5.00
Long Spacer	KURT-6AWS-289	\$5.00

VISE WORK STOP

Fits Anglock type vises

BEST VALUE



- Single thumb screw tightens clamp to vise jaw.
- Two ground pins on both sides of clamp.
- Easily mounts to the top of most vise jaws.
- 1 piece clamping screws.
- 7/8" Capacity.

Capacity	Part Number	Price
7/8"	VWS-875	\$9.95

MILLING VISE WORK STOPS

BEST VALUE



FEATURES:

- Permits Fast, completely accurate positioning of repetitive work.
- Weight: 0.18 lbs.

For 6" Vises

Vise Size	Part Number	Price
6" Vises	MVS-600	\$22.95

ADJUSTABLE UNIVERSAL WORKSTOP

BEST VALUE



- Serves as a rigid stop for milling setups.
- For use with vises, angle plates and jigs.
- Usable as a versatile holder, as well as a workstop.

Specifications:
Column: 3/4" x 6-1/4"
Base: 3/4" x 2" x 4-1/2"
Rod: 3/8" x 10"
Weight: 3.4 lbs

Description	Part Number	Price
Universal Workstop	AUS-600	\$14.95

ULTIMATE 5-AXIS WORK STOP TOOL

New advanced single mount, swivel-action work stop tool for cnc machine centers, milling machines and drill presses.

FEATURES:

- Saves time and increases efficiency.
- Fast set-up time.
- Quick and accurate repetitive positioning.
- Locks in rigid.
- Quick/universal machine installation.
- Versatile job applications.

Size	Color	Part Number	Price
6"	Purple	A-1-P6-5A	\$72.00
8"	Red	A-1-R8-5A	\$149.00
10"	Yellow	A-1-Y10-5A	\$175.00



Pivoting/Positioning Rigid Locking System

Call Us Today For All Of Your Machine Tool Needs!

WISE ACCESSORIES

LATHE CHUCKS
LIVE CENTERS

WISE JAWS
WISE ACCESSORIES

STRAIGHT SHANK
COLLET HOLDERS

LATHE BUSHINGS
DRILL CHUCKS

CARBIDE INSERTS
THREADING/GROOVING

CUTTING TOOLS
MACHINERY

PRECISION TOOLS
DEBURRING

COOLANT/FLUIDS
TOOL STORAGE



PRIDE
PRODUCTS

PARALLEL KEEPER

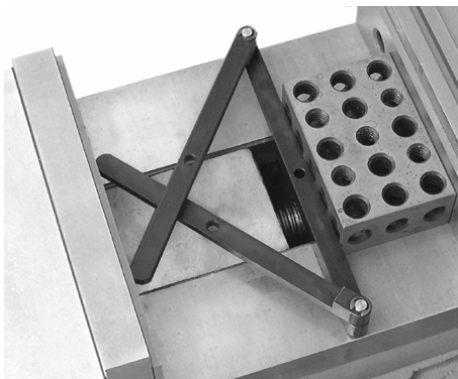

The fast and easy way to hold parallels in place while automatically self-adjusting to a wide range of vise movements and openings. EZ-Keep's magnetic base holds firmly against one parallel, automatically adjusting to any vise movement while holding parallel in place.

- Reduce set-up time
- Keeps parallels in place
- Magnetic base-can be stored on side of vise!
- Compact, narrow & low profile
- Made in USA

Additional Parallel Sets
Are Located On Page 525



PARALLEL KEEPER
Part # SL-EZKEEP

\$24.95 each

PARALLEL KEEPER

Place your parallels in the vise against the jaws. Take the Parallel Keeper, squeeze it together and place it inside the parallels. Release the Parallel Keeper, it will push against the parallels, holding them against the jaws of the vise! Opens to 6 inches. Saves you part change time!

Fits 6" Vises!

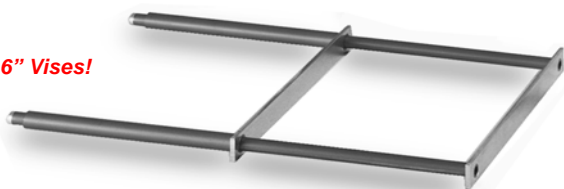

Description	Part Number	Price
Parallel Keeper	KURT-KPS-6000	\$62.00



ADJUSTABLE PARALLELS



- Two precision ground pieces
- Locked into position by set screws
- Can be quickly inserted into openings and expanded to exact size, then measured with a micrometer
- Supplied with screwdriver
- Made in USA

Description	Part Number	Price
6 Pc Adjustable Parallel Set	PEC-S-112-6	\$77.55

MAGNETIC JAW PLATES

Features powerful earth magnets for holding parallels securely in place, leaving hands free to hold and clamp the workpiece. Perfect for fast and accurate set ups.

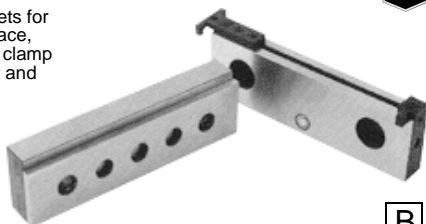

Description	Length	Width	Height	Part Number	Price
6" Magnetic Jaw Plate	5.969	.725	1.735	KURT-D60-7-MAG	\$46.00
6" for Groove Lock Workstops	5.969	.725	1.735	KURT-D60-315-MA	\$49.00



MAGNETIC JAW PLATE AND PARALLEL SET

Fits all Kurt 6 inch vises!

11 Piece Set Includes:

- 2 ea.- 3/16" x 1" x 6" ground steel parallels.
- 2 ea.- 3/16" x 1 1/4" x 6" ground steel parallels.
- 2 ea.- 3/16" x 1 3/4" x 6" ground steel parallels.
- 1 ea.- D60-7-MAG hardened jaw plate with earth magnet.
- 1 ea.- D60-315-MAG hardened Groove Lock jaw plate with earth magnet.
- 1 ea.- WSR46 Kurt Groove Lock Workstop.
- 1 ea.- WSR46 Kurt Groove Lock extended workstop.
- 1 ea.- Wooden storage box.



Description	Part Number	Price
Magnetic Jaw Plate/Parallel Set	KURT-6PJS	\$131.00

ECONOMY 1/4" PARALLEL SET

FEATURES:

- Made from high quality tool steel
- Stress relieved against distortion
- Precision ground and hardened
- Ideal for layout work and set-ups
- 9 pairs, 1/4" thick, 6" Length
- Heights: 3/4", 7/8", 1", 1-1/8", 1-1/4", 1-3/8", 1-1/2", 1-5/8" and 1-3/4"
- Parallel to 0.0003 on top & bottom
- Complete with durable fitted plastic case

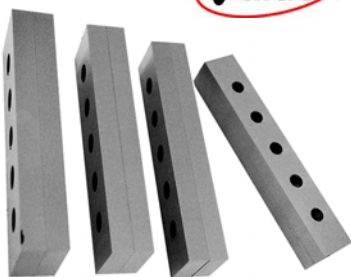

Description	Length	Part Number	Price
9 Pair Set	1/4" W X 6" L	A-3900-3009	\$65.00



ECONOMY 1/8" PARALLEL SET

FEATURES:

- Made from high quality tool steel
- Stress relieved against distortion
- Precision ground and hardened
- 1/8" thick with 2 holes in each parallel
- 10 pairs, 6" Length
- Heights: 1/2", 5/8", 3/4", 7/8", 1", 1-1/8", 1-1/4", 1-3/8", 1-1/2" and 1-5/8"
- Complete with durable fitted plastic case



Description	Length	Part Number	Price
10 Pair Set	1/8" W X 6" L	A-3900-3010	\$42.50

Call Us Or Visit Our Website For Our Complete Selection!

2010-11 Master Catalog