

CHUCK JAWS
LATHE WORKHOLDING

MACHINE VISES
MAGNETIC CHUCKS

RETENTION KNOBS
ER, DA, TG COLLETS

TOOLHOLDERS
TAP HOLDERS

INDEXABLE DRILLS
TURNING & BORING

ENDMILLS, DRILLS
TAPS & REAMERS

ABRASIVES
MEASURING TOOLS

MRO & SAFETY
FLAT STOCK/DRILL ROD

SPADE DRILL BODIES- STRAIGHT SHANK

SPADE DRILL BODIES
Straight Shank, Straight Flute

ALLIED™ "TA" Series Compatible!



Prices Are
50%
Below Mfg's List!

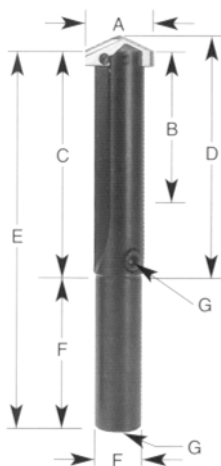
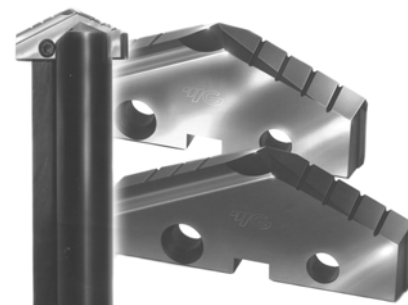

Short Length - Straight Shank Holders, Straight Flute

Series	A	B	C	D	E	F	F	G	Part Number	Price Each
	Drill Insert Range (inches)	Max Drill Depth	Flute Length	Ref Length	OAL	Shank Dia	Shank Length	Pipe Tap		
Y	3/8 to 27/64	1 1/4	2-1/32	2 1/8	4 13/32	3/4	2 3/8	1/8	YG-P13Y01	\$118.10
Z	7/16 to 1/2	1 1/4	2-1/32	2 1/8	4 13/32	3/4	2 3/8	1/8	YG-P13Z01	\$118.10
0	33/64 to 11/16	1 3/8	2-3/16	2 19/64	4 9/16	3/4	2 3/8	1/8	YG-P13001	\$118.10
0.5	39/64 to 11/16	1 3/8	2-3/16	2 19/64	4 9/16	3/4	2 3/8	1/8	YG-P13051	\$118.10
1	45/64 to 15/16	2 5/8	3-7/8	4 1/64	6 7/8	3/4	3	1/8	YG-P13101	\$122.61
						1	3	1/8	YG-P13102	\$122.61
1.5	66/64 to 15/16	2 5/8	3-7/8	4 1/64	6 7/8	3/4	3	1/8	YG-P13151	\$132.53
						1	3	1/8	YG-P13152	\$132.53
2	31/32 to 1 3/8	3 3/8	4-1/2	4 41/64	8	1	3 1/2	1/8	YG-P13202	\$132.53
						1-1/4	3 1/2	1/8	YG-P13203	\$132.53
2.5	1 3/16 to 1 3/8	3 3/8	4-1/2	4 41/64	8	1	3 1/2	1/8	YG-P13252	\$148.75
						1-1/4	3 1/2	1/8	YG-P13253	\$148.75
3	1 13/32 to 1 7/8	4 3/4	6	6 3/16	10	1-1/4	4	1/4	YG-P13303	\$150.56
						1-1/2	4	1/4	YG-P13304	\$150.56
4	1 29/32 to 2 9/16	5 1/8	6-1/2	6 11/16	10 1/2	1-1/2	4	1/4	YG-P13404	\$173.09
						1-3/4	4	1/4	YG-P13405	\$183.01
5	2 1/2 to 3 1/2	6 3/4	8-1/2	8 3/4	12 1/2	2	4	1/2	YG-P13506	\$274.96
7-8	3 17/32 to 4 1/2	6 3/4	8-7/8	9 1/8	13 7/8	3	5	1/2	YG-P13708	\$374.13

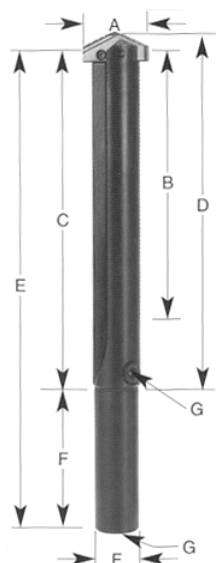

Standard Length - Straight Shank Holders, Straight Flute

Series	A	B	C	D	E	F	F	G	Part Number	Price Each
	Drill Insert Range (inches)	Max Drill Depth	Flute Length	Ref Length	OAL	Shank Dia	Shank Length	Pipe Tap		
Y	3/8 to 27/64	2 3/8	3-5/32	3 1/4	5 17/32	3/4	2 3/8	1/8	YG-P15Y01	\$120.81
Z	7/16 to 1/2	2 3/8	3-5/32	3 1/4	5 17/32	3/4	2 3/8	1/8	YG-P15Z01	\$120.81
0	33/64 to 11/16	2 1/2	3-5/16	3 27/64	5 11/16	3/4	2 3/8	1/8	YG-P15001	\$120.81
0	39/64 to 11/16	2 1/2	3 5/16	3 27/64	5 11/16	3/4	2 3/8	1/8	YG-P15051	\$120.81
1	45/64 to 15/16	6 5/8	7-7/8	8 1/64	10 7/8	3/4	3	1/8	YG-P15101	\$132.53
						1	3	1/8	YG-P15102	\$132.53
1.5	55/64 to 15/16	6 5/8	7-7/8	8 1/64	10 7/8	3/4	3	1/8	YG-P15151	\$142.44
						1	3	1/8	YG-P15152	\$142.44
2	31/32 to 1 3/8	7 3/8	8-1/2	8 41/64	12	1	3 1/2	1/8	YG-P15202	\$142.44
						1-1/4	3 1/2	1/8	YG-P15203	\$142.44
2.5	1 3/16 to 1 3/8	7 3/8	8-1/2	8 41/64	12	1	3 1/2	1/8	YG-P15252	\$157.77
						1-1/4	3 1/2	1/8	YG-P15253	\$157.77
3	1 13/32 to 1 7/8	8 1/4	9-1/2	9 11/16	13 1/2	1-1/4	4	1/4	YG-P15303	\$159.57
						1-1/2	4	1/4	YG-P15304	\$159.57
4	1 29/32 to 2 9/16	9 1/8	10-1/2	10 11/16	14 1/2	1-1/2	4	1/4	YG-P15404	\$200.14
						1-3/4	4	1/4	YG-P15405	\$215.46
5	2 1/2 to 3 1/2	10 3/4	12-1/2	12 3/4	16 1/2	2	4	1/2	YG-P15506	\$302.01
7-8	3 17/32 to 4 1/2	10 3/4	12-7/8	13 1/8	17 7/8	3	5	1/2	YG-P15708	\$446.25

ALLIED is a trademark of Allied Machine and Engineering Corporation.

Call Us Today For All Of Your Machine Tool Needs!

2010-11 Master Catalog

SPADE DRILL BODIES- TAPER SHANK

SPADE DRILL BODIES

Morse Taper Shank, Straight Flute

ALLIED™ "TA" Series Compatible!

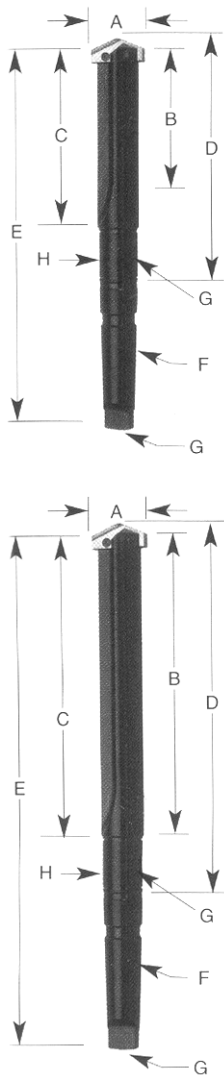

Short Length- Morse Taper Shank, Straight Flute

Insert Series	A	B	C	D	E	F	G	Part Number	Price Each	Coolant Inducer
Y	3/8 -27/64	1-1/4	2-1/32	3-15/32	6-5/16	#2	1/16	YG-P01Y02	\$125.05	YG-PR1030
Z	7/16 -1/2	1-1/4	2-1/32	3-15/32	6-5/16	#2	1/16	YG-P01Z02	\$125.05	
0	33/64 -11/16	1-3/8	2-3/16	3-41/64	6-15/32	#2	1/16	YG-P01002	\$125.05	
0.5	39/64 -11/16	1-3/8	2-3/16	3-41/64	6-15/32	#2	1/16	YG-P01052	\$125.05	YG-PR1031
1	45/64 -15/16	2-3/4	3-7/8	5-39/64 5-43/64	9-5/32 10-5/32	#3 #4	1/8	YG-P01103 YG-P01104	\$136.50 \$140.32	
1.5	55/64 -15/16	2-3/4	3-7/8	5-39/64 5-43/64	9-5/32 10-5/32	#3 #4	1/8	YG-P01153 YG-P01154	\$147.00 \$151.78	YG-PR1031
2	31/32 -1-3/8	3-3/8	4-1/2	6-15/64 6-19/64	9-25/32 10-25/32	#3 #4	1/8	YG-P01203 YG-P01204	\$151.78 \$157.50	YG-PR1031
2.5	1-3/16 -1-3/8	3-3/8	4-1/2	6-15/64 6-37/64	9-25/32 11-1/16	#3 #4	1/8 1/4	YG-P01253 YG-P01254	\$162.28 \$168.96	YG-PR1031 YG-PR1042
3	1-13/32 -1-7/8	4-3/4	6	8-1/8 8-1/8	12-9/16 13-13/16	#4 #5	1/4	YG-P01304 YG-P01305	\$168.96 \$178.50	YG-PR1042 YG-PR1043
4	1-29/32 -2-9/16	5-1/8	6-1/2	8-5/8 8-5/8	13-1/16 14-5/16	#4 #5	1/4	YG-P01404 YG-P01405	\$183.28 \$200.46	YG-PR1042 YG-PR1043
5	2-1/2 -3-1/2	6-3/4	8-1/2	11-5/16	16-15/16	#5	1/2	YG-P01505	\$291.14	YG-PR1054
7	3-17/32 -4-1/2	6-3/4	8-7/8	11-11/16	17-5/16	#5	1/2	YG-P01705	\$396.14	YG-PR1054

Standard Length- Morse Taper Shank, Straight Flute

Insert Series	A	B	C	D	E	F	G	Part Number	Price Each	Coolant Inducer
Y	3/8 -27/64	2-3/8	3-5/32	4-19/32	7-7/16	#2	1/16	YG-P03Y02	\$127.91	YG-PR1030
Z	7/16 -1/2	2-3/8	3-5/32	4-19/32	7-7/16	#2	1/16	YG-P03Z02	\$127.91	
0	33/64 -11/16	2-1/2	3-5/16	4-49/64	7-19/32	#2	1/16	YG-P03002	\$127.91	
0.5	39/64 -11/16	2 1/2	3-5/16	4-49/64	7-19/32	#2	1/16	YG-P03052	\$127.91	YG-PR1031
1	45/64 -15/16	6-3/4	7-7/8	9-39/64 9-43/64	13-5/32 14-5/32	#3 #4	1/8	YG-P03103 YG-P03104	\$146.05 \$150.82	
1.5	55/64 -15/16	6-3/4	7-7/8	9-39/64 9-43/64	13-5/32 14-5/32	#3 #4	1/8	YG-P03153 YG-P03154	\$156.55 \$161.32	YG-PR1031
2	31/32 -1-3/8	7-3/8	8-1/2	10-15/64 10-19/64	13-25/32 14-25/32	#3 #4	1/8	YG-P03203 YG-P03204	\$161.32 \$166.09	YG-PR1031
2.5	1-3/16 -1-3/8	7-3/8	8-1/2	10-15/64 10-37/64	13-25/32 15-1/16	#3 #4	1/8 1/4	YG-P03253 YG-P03254	\$171.82 \$178.50	YG-PR1031 YG-PR1042
3	1-13/32 -1-7/8	8-1/4	9-1/2	11-5/8 11-5/8	16-1/16 17-5/16	#4 #5	1/4	YG-P03304 YG-P03305	\$184.23 \$198.55	YG-PR1042 YG-PR1043
4	1-29/32 -2-9/16	9-1/8	10-1/2	12-5/8 12-5/8	17-1/16 18-5/16	#4 #5	1/4	YG-P03404 YG-P03405	\$211.91 \$228.14	YG-PR1042 YG-PR1043
5	2-1/2 -3-1/2	10-3/4	12-1/2	15-5/16	20-5/16	#5	1/2	YG-P03505	\$319.78	YG-PR1054
7	3-17/32 -4-1/2	10-3/4	12-7/8	15-11/16	21-5/16	#5	1/2	YG-P03705	\$472.50	

Coolant Inducers Are Located On Page 232

INTERMEDIATE LENGTH HOLDERS

Intermediate Length Taper Shank Holder- Helical Flute

Series	Allied Ref. Number	Drill Insert Range	Max. Drill Depth	Flute Length	Ref. Length	OAL	MT	Pipe Tap	Part Number	Price Each
1	23010H - 003I	45/64" - 15/16	4-3/4	5-7/8	7-39/64	11-5/32	#3	1/8	YG-P08103	\$156.97
1.5	23015H - 003I	55/64" - 15/16	4-3/4	5-7/8	7-39/64	11-5/32	#3	1/8	YG-P08153	\$169.70
2	23020H - 004I	31/32" - 1-3/8	5-3/8	6-1/2	8-19/64	12-25/32	#4	1/8	YG-P08204	\$180.31
2.5	23025H - 004I	1-3/16" - 1-3/8	5-3/8	6-1/2	8-37/64	13-1/16	#4	1/4	YG-P08254	\$193.03

Intermediate Length Straight Shank Holder- Straight Flute

Series	Allied Ref. Number	Drill Insert Range	Max. Drill Depth	Flute Length	Ref. Length	OAL	Shank Dia.	Shank Length	Pipe Tap	Part Number	Price Each
1	23010S - 100L	45/64" - 15/16	4-5/8	5-7/8	6-1/64	8-7/8	1	3	1/8	YG-P14102	\$140.00
1.5	23015S - 100L	55/64" - 15/16	4-5/8	5-7/8	6-1/64	8-7/8	1	3	1/8	YG-P14152	\$152.73
2	23020S - 125L	31/32" - 1-3/8	5-3/8	6-1/2	6-41/64	10	1-1/4	3-1/2	1/8	YG-P14203	\$152.73
2.5	23025S - 125L	1-3/16" - 1-3/8	5-3/8	6-1/2	6-41/64	10	1-1/4	3-1/2	1/8	YG-P14253	\$169.70
3	23030S - 150L	1-13/32" - 1-7/8	6-1/2	7-3/4	7-15/16	11-3/4	1-1/2	4	1/4	YG-P14304	\$180.31

Call Us Or Visit Our Website For Our Complete Selection!

2010-11 Master Catalog

273

LATHES CHUCKS
LIVE CENTERS
VISE ACCESSORIES
VISE JAWS
STRAIGHT SHANK COLLET HOLDERS
LATHES BUSHINGS
DRILL CHUCKS
CARBIDE INSERTS
THREADING/GROOVING
CUTTING TOOLS
MACHINERY
PRECISION TOOLS
DEBURRING
COOLANT/FLUIDS
TOOL STORAGE



CHUCK JAWS
LATHE WORKHOLDING

MACHINE VISES
MAGNETIC CHUCKS

RETENTION KNOBS
ER, DA, TG COLLETS

TOOLHOLDERS
TAP HOLDERS

INDEXABLE DRILLS
TURNING & BORING

ENDMILLS, DRILLS
TAPS & REAMERS

ABRASIVES
MEASURING TOOLS

MRO & SAFETY
FLAT STOCK/DRILL ROD

SPADE DRILL INSERTS-HSS

"THROW AWAY" SPADE DRILL INSERTS Super HSS M4 & T15

HSS M-4:

- Loose machines
- Manual machines
- If T-15 breaks
- Cross hole drilling



HSS T-15:

- On CNC machines
- When M-4 life needs to be extended
- Abrasive drilling



Prices Are
50%
Below Mfg's List!



ALLIED™ "TA" Series Compatible!

Inch Dia	Dec Dia	SUPER HSS T-15		SUPER HSS M-4	
		T15 TiN Part Number	T15 TiAIN Part Number	M4 TiN Part Number	M4 TiAIN Part Number
Series Y 3/32" Thick		\$15.29 ea.	\$18.37 ea.	-	-
9.5mm	0.3740	YG-S06Y01	YG-S08Y01	-	-
3/8	0.3750	YG-S06Y02	YG-S08Y02	-	-
25/64	0.3906	YG-S06Y04	YG-S08Y04	-	-
10.0mm	0.3937	YG-S06Y05	YG-S08Y05	-	-
13/32	0.4063	YG-S06Y07	YG-S08Y07	-	-
10.5mm	0.4134	YG-S06Y08	YG-S08Y08	-	-
27/64	0.4219	YG-S06Y09	YG-S08Y09	-	-
11.0mm	0.4331	YG-S06Y11	YG-S08Y11	-	-
Series Z 3/32" Thick		\$15.29 ea.	\$18.37 ea.	-	-
7/16	0.4375	YG-S06Z01	YG-S08Z01	-	-
11.50mm	0.4528	YG-S06Z02	YG-S08Z02	-	-
29/64	0.4531	YG-S06Z03	YG-S08Z03	-	-
15/32	0.4688	YG-S06Z04	YG-S08Z04	-	-
12.0mm	0.4724	YG-S06Z05	YG-S08Z05	-	-
31/64	0.4844	YG-S06Z06	YG-S08Z06	-	-
12.5mm	0.4921	YG-S06Z07	YG-S08Z07	-	-
1/2	0.5000	YG-S06Z08	YG-S08Z08	-	-
Series 0 1/8" Thick		\$16.50 ea.	\$19.80 ea.	-	-
13.0mm	0.5118	YG-S06001	YG-S08001	-	-
33/64	0.5156	YG-S06002	YG-S08002	-	-
17/32	0.5313	YG-S06003	YG-S08003	-	-
13.5mm	0.5315	YG-S06004	YG-S08004	-	-
35/64	0.5469	YG-S06060	YG-S08060	-	-
14.0mm	0.5512	YG-S06005	YG-S08005	-	-
9/16	0.5625	YG-S06006	YG-S08006	-	-
14.5mm	0.5709	YG-S06007	YG-S08007	-	-
37/64	0.5781	YG-S06008	YG-S08008	-	-
15.0mm	0.5906	YG-S06009	YG-S08009	-	-
19/32	0.5938	YG-S06010	YG-S08010	-	-
39/64	0.6094	YG-S06061	YG-S08061	-	-
15.5mm	0.6102	YG-S06011	YG-S08011	-	-
5/8	0.6250	YG-S06012	YG-S08012	-	-
16.0mm	0.6299	YG-S06013	YG-S08013	-	-
41/64	0.6406	YG-S06062	YG-S08062	-	-
16.5mm	0.6496	YG-S06014	YG-S08014	-	-
21/32	0.6563	YG-S06015	YG-S08015	-	-
17.0mm	0.6693	YG-S06016	YG-S08016	-	-
43/64	0.6719	YG-S06063	YG-S08063	-	-
11/16	0.6875	YG-S06017	YG-S08017	-	-
17.5mm	0.6890	YG-S06018	YG-S08018	-	-

Inch Dia	Dec Dia	SUPER HSS T-15		SUPER HSS M-4	
		T15 TiN Part Number	T15 TiAIN Part Number	M4 TiN Part Number	M4 TiAIN Part Number
Series 1 (cont.) 5/32" Thick		\$18.57 ea.	\$22.00 ea.	\$16.50 ea.	\$19.80 ea.
45/64	0.7031	YG-S06101	YG-S08101	YG-S01101	YG-S03101
18mm	0.7087	YG-S06102	YG-S08102	YG-S01102	YG-S03102
23/32	0.7188	YG-S06103	YG-S08103	YG-S01103	YG-S03103
18.5mm	0.7283	YG-S06104	YG-S08104	YG-S01104	YG-S03104
47/64	0.7344	YG-S06105	YG-S08105	YG-S01105	YG-S03105
19.0mm	0.7480	YG-S06106	YG-S08106	YG-S01106	YG-S03106
3/4	0.7500	YG-S06107	YG-S08107	YG-S01107	YG-S03107
49/64	0.7656	YG-S06108	YG-S08108	YG-S01108	YG-S03108
19.5mm	0.7677	YG-S06109	YG-S08109	YG-S01109	YG-S03109
25/32	0.7813	YG-S06110	YG-S08110	YG-S01110	YG-S03110
20.0mm	0.7874	YG-S06111	YG-S08111	YG-S01111	YG-S03111
51/64	0.7969	YG-S06160	YG-S08160	YG-S01160	YG-S03160
20.5mm	0.8071	YG-S06112	YG-S08112	YG-S01112	YG-S03112
13/16	0.8125	YG-S06113	YG-S08113	YG-S01113	YG-S03113
21.0mm	0.8268	YG-S06114	YG-S08114	YG-S01114	YG-S03114
27/32	0.8438	YG-S06115	YG-S08115	YG-S01115	YG-S03115
55/64	0.8594	YG-S06161	YG-S08161	YG-S01161	YG-S03161
22.0mm	0.8661	YG-S06116	YG-S08116	YG-S01116	YG-S03116
7/8	0.8750	YG-S06117	YG-S08117	YG-S01117	YG-S03117
57/64	0.8906	YG-S06162	YG-S08162	YG-S01162	YG-S03162
23.0mm	0.9055	YG-S06118	YG-S08118	YG-S01118	YG-S03118
29/32	0.9063	YG-S06119	YG-S08119	YG-S01119	YG-S03119
59/64	0.9219	YG-S06120	YG-S08120	YG-S01120	YG-S03120
15/16	0.9375	YG-S06121	YG-S08121	YG-S01121	YG-S03121
24.0mm	0.9449	YG-S06122	YG-S08122	YG-S01122	YG-S03122
Series 2 3/16" Thick		\$21.87 ea.	\$25.94 ea.	\$19.39 ea.	\$23.27 ea.
31/32	0.9688	YG-S06201	YG-S08201	YG-S01201	YG-S03201
63/64	0.9844	YG-S06202	YG-S08202	YG-S01202	YG-S03202
1	1.0000	YG-S06203	YG-S08203	YG-S01203	YG-S03203
1-1/64	1.1667	YG-S06204	YG-S08204	YG-S01204	YG-S03204
26.0mm	1.0236	YG-S06205	YG-S08205	YG-S01205	YG-S03205
1-1/32	1.0313	YG-S06206	YG-S08206	YG-S01206	YG-S03206
1-3/64	1.0469	YG-S06260	YG-S08260	YG-S01260	YG-S03260
1-1/16	1.0625	YG-S06207	YG-S08207	YG-S01207	YG-S03207
27.0mm	1.0630	YG-S06208	YG-S08208	YG-S01208	YG-S03208
1-3/32	1.0938	YG-S06209	YG-S08209	YG-S01209	YG-S03209
28.0mm	1.1024	YG-S06210	YG-S08210	YG-S01210	YG-S03210
1-7/64	1.1094	YG-S06261	YG-S08261	YG-S01261	YG-S03261
1-1/8	1.1250	YG-S06211	YG-S08211	YG-S01211	YG-S03211
29.0mm	1.1417	YG-S06212	YG-S08212	YG-S01212	YG-S03212
1-5/32	1.1563	YG-S06213	YG-S08213	YG-S01213	YG-S03213
30.0mm	1.1811	YG-S06214	YG-S08214	YG-S01214	YG-S03214
1-3/16	1.1875	YG-S06215	YG-S08215	YG-S01215	YG-S03215
1-7/32	1.2188	YG-S06216	YG-S08216	YG-S01216	YG-S03216
31.0mm	1.2205	YG-S06217	YG-S08217	YG-S01217	YG-S03217
1-1/4	1.2500	YG-S06218	YG-S08218	YG-S01218	YG-S03218
32.0mm	1.2598	YG-S06219	YG-S08219	YG-S01219	YG-S03219
1-9/32	1.2813	YG-S06220	YG-S08220	YG-S01220	YG-S03220
33.0mm	1.2992	YG-S06221	YG-S08221	YG-S01221	YG-S03221
1-5/16	1.3125	YG-S06222	YG-S08222	YG-S01222	YG-S03222
1-1/32	1.3333	YG-S06206	YG-S08206	YG-S01206	YG-S03206
34.0mm	1.3386	YG-S06223	YG-S08223	YG-S01223	YG-S03223
1-11/32	1.3438	YG-S06224	YG-S08224	YG-S01224	YG-S03224
1-3/8	1.3750	YG-S06225	YG-S08225	YG-S01225	YG-S03225
35.0mm	1.3780	YG-S06226	YG-S08226	YG-S01225	YG-S03226

Call Us Today For All Of Your Machine Tool Needs!

SPADE DRILL INSERTS-HSS

"THROW AWAY" SPADE DRILL INSERTS

Super HSS M4 & T15

When to use:

HSS M-4:

- Loose machines
- Manual machines
- If T-15 breaks
- Cross hole drilling

HSS T-15:

- On CNC machines
- When M-4 life needs to be extended
- Abrasive drilling

Prices Are
50%
Below Mfg's List!



COOLANT INDUCERS FOR MORSE TAPER DRILLS

Complete with "O" rings, flat washers
and locking clips

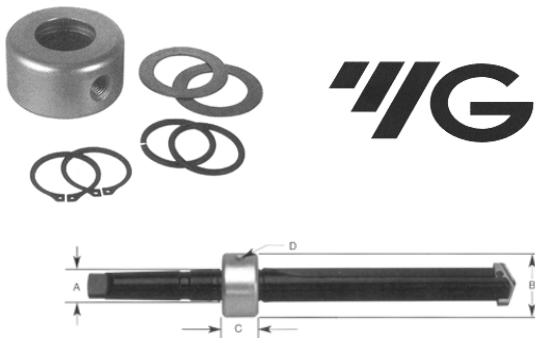

A	B	C	D	E	Part Number	Price Each
I.D.	Pipe O.D.	Length	Thread for Driving Rod	Pipe Tap		
3/4	1-3/4	7/8	1-3/4	1/8	YG-PR1030	\$32.64
1	2-1/8	1-1/8	2-1/8	1/8	YG-PR1031	\$36.06
1-1/4	2-1/2	1-3/8	2-1/2	1/4	YG-PR1042	\$44.18
1-3/4	3	1-3/8	3	1/4	YG-PR1043	\$50.49
2-1/4	3-3/4	1-3/4	3-3/4	1/2	YG-PR1054	\$61.31

ALLIED™ "TA" Series Compatible!

Inch Dia	Dec Dia	SUPER HSS T-15		SUPER HSS M-4	
		T15 TIN Part Number	T15 TiAIN Part Number	M4 TIN Part Number	M4 TiAIN Part Number
Series 3 1/4" Thick		\$27.75 ea.	\$33.28 ea.	\$24.09 ea.	\$28.99 ea.
1-13/32	1.4063	YG-S06301	YG-S08301	YG-S01301	YG-S03301
36.0mm	1.4173	YG-S06302	YG-S08302	YG-S01302	YG-S03302
1-7/16	1.4375	YG-S06303	YG-S08303	YG-S01303	YG-S03303
37.0mm	1.4567	YG-S06304	YG-S08304	YG-S01304	YG-S03304
1-15/32	1.4688	YG-S06305	YG-S08305	YG-S01305	YG-S03305
38.0mm	1.4961	YG-S06306	YG-S08306	YG-S01306	YG-S03306
1-1/2	1.5000	YG-S06307	YG-S08307	YG-S01307	YG-S03307
1-17/32	1.5313	YG-S06308	YG-S08308	YG-S01308	YG-S03308
39.0mm	1.5354	YG-S06309	YG-S08309	YG-S01309	YG-S03309
1-9/16	1.5625	YG-S06310	YG-S08310	YG-S01310	YG-S03310
40.0mm	1.5748	YG-S06311	YG-S08311	YG-S01311	YG-S03311
1-19/32	1.5938	YG-S06312	YG-S08312	YG-S01312	YG-S03312
41.0mm	1.6142	YG-S06313	YG-S08313	YG-S01313	YG-S03313
1-5/8	1.6250	YG-S06314	YG-S08314	YG-S01314	YG-S03314
42.0mm	1.6535	YG-S06315	YG-S08315	YG-S01315	YG-S03315
1-21/32	1.6563	YG-S06316	YG-S08316	YG-S01316	YG-S03316
1-11/16	1.6875	YG-S06317	YG-S08317	YG-S01317	YG-S03317
43.0mm	1.6929	YG-S06318	YG-S08318	YG-S01318	YG-S03318
1-23/32	1.7188	YG-S06319	YG-S08319	YG-S01319	YG-S03319
44.0mm	1.7323	YG-S06320	YG-S08320	YG-S01320	YG-S03320
1-3/4	1.7500	YG-S06321	YG-S08321	YG-S01321	YG-S03321
45.0mm	1.7717	YG-S06322	YG-S08322	YG-S01322	YG-S03322
1-25/32	1.7813	YG-S06323	YG-S08323	YG-S01323	YG-S03323
46.0mm	1.8110	YG-S06324	YG-S08324	YG-S01324	YG-S03324
1-13/16	1.8125	YG-S06325	YG-S08325	YG-S01325	YG-S03325
1-27/32	1.8438	YG-S06326	YG-S08326	YG-S01326	YG-S03326
47.0mm	1.8504	YG-S06327	YG-S08327	YG-S01327	YG-S03327
1-7/8	1.8750	YG-S06328	YG-S08328	YG-S01328	YG-S03328
Series 4 5/16" Thick		\$35.12 ea.	\$42.06 ea.	\$28.59 ea.	\$34.30 ea.
1-29/32	1.9063	YG-S06402	YG-S08402	YG-S01402	YG-S03402
1-15/16	1.9375	YG-S06404	YG-S08404	YG-S01404	YG-S03404
1-31/32	1.9688	YG-S06406	YG-S08406	YG-S01406	YG-S03406
2	2.000	YG-S06407	YG-S08407	YG-S01407	YG-S03407
2-1/32	2.0313	YG-S06409	YG-S08409	YG-S01409	YG-S03409
2-3/64	2.0469	YG-S06410	YG-S08410	YG-S01410	YG-S03410
2-1/16	2.0625	YG-S06411	YG-S08411	YG-S01411	YG-S03411
2-3/32	2.0938	YG-S06413	YG-S08413	YG-S01413	YG-S03413
2-1/8	2.1250	YG-S06414	YG-S08414	YG-S01414	YG-S03414
2-5/32	2.1563	YG-S06416	YG-S08416	YG-S01416	YG-S03416
2-3/16	2.1875	YG-S06418	YG-S08418	YG-S01418	YG-S03418
2-7/32	2.2188	YG-S06420	YG-S08420	YG-S01420	YG-S03420
2-1/4	2.2500	YG-S06422	YG-S08422	YG-S01422	YG-S03422
2-9/32	2.2813	YG-S06423	YG-S08423	YG-S01423	YG-S03423
2-5/16	2.3125	YG-S06425	YG-S08425	YG-S01425	YG-S03425
2-11/32	2.3438	YG-S06427	YG-S08427	YG-S01427	YG-S03427
2-3/8	2.3750	YG-S06429	YG-S08429	YG-S01429	YG-S03429
2-13/32	2.4063	YG-S06431	YG-S08431	YG-S01431	YG-S03431
2-7/16	2.4375	YG-S06432	YG-S08432	YG-S01432	YG-S03432
2-15/32	2.4688	YG-S06434	YG-S08434	YG-S01434	YG-S03434
2-1/2	2.5000	YG-S06436	YG-S08436	YG-S01436	YG-S03436
2-17/32	2.5313	YG-S06438	YG-S08438	YG-S01438	YG-S03438
2-9/16	2.5625	YG-S06440	YG-S08440	YG-S01440	YG-S03440

LATHE CHUCKS
LIVE CENTERS

VICE JAWS
VICE ACCESSORIES

STRAIGHT SHANK
COLLET HOLDERS

LATHE BUSHINGS
DRILL CHUCKS

CARBIDE INSERTS
THREADING/ROOVING

CUTTING TOOLS
MACHINERY

PRECISION TOOLS
DEBURRING

COOLANT/FLUIDS
TOOL STORAGE

Call Us Or Visit Our Website For Our Complete Selection!

2010-11 Master Catalog

275

SPADE DRILL INSERTS-CARBIDE

"THROW AWAY" SPADE DRILL INSERTS

Carbide

CHUCK JAWS
LATHE WORKHOLDING

MACHINE VISES
MAGNETIC CHUCKS

RETENTION KNOBS
ER, DA, TG COLLETS

TOOLHOLDERS
TAP HOLDERS

INDEXABLE DRILLS
TURNING & BORING

ENDMILLS, DRILLS
TAPS & REAMERS

ABRASIVES
MEASURING TOOLS

MRO & SAFETY
FLAT STOCK/DRILL ROD



Grade Information:
C-5- Steel Cutting
C-3- Cast Iron
C-2- Ductile Iron
Stainless Steel
Aluminum
Exotic Alloys



ALLIED™ Compatible!

Prices Are
50%
Below Mfg's List!

Series Min-Max	Inch Dia	Metric Dia	Dec Dia	TIN C2 Part Number	TIALN C2 Part Number	Hardslick C2 Part Number	TIN C5 Part Number	TIALN C5 Part Number	Hardslick C5 Part Number	
Series Y Carbide Inserts				\$26.34ea.	\$28.38ea.	\$25.80 ea.	\$26.34 ea.	\$28.38ea.	\$25.80 ea.	
Y 9.5mm (.374") to 11.07mm (.436") 3/32 Thick	3/8	9.5	.3740	YG-S21Y01	YG-S23Y01	YG-S24Y01	YG-S26Y01	YG-S28Y01	YG-S29Y01	
		9.53	.3750	YG-S21Y02	YG-S23Y02	YG-S24Y02	YG-S26Y02	YG-S28Y02	YG-S29Y02	
		9.8	.3860	YG-S21Y03	YG-S23Y03	YG-S24Y03	YG-S26Y03	YG-S28Y03	YG-S29Y03	
	25/64	9.92	.3906	YG-S21Y04	YG-S23Y04	YG-S24Y04	YG-S26Y04	YG-S28Y04	YG-S29Y04	
		10	.3937	YG-S21Y05	YG-S23Y05	YG-S24Y05	YG-S26Y05	YG-S28Y05	YG-S29Y05	
		10.2	.4016	YG-S21Y06	YG-S23Y06	YG-S24Y06	YG-S26Y06	YG-S28Y06	YG-S29Y06	
	13/32	10.32	.4063	YG-S21Y07	YG-S23Y07	YG-S24Y07	YG-S26Y07	YG-S28Y07	YG-S29Y07	
		10.5	.4134	YG-S21Y08	YG-S23Y08	YG-S24Y08	YG-S26Y08	YG-S28Y08	YG-S29Y08	
		10.72	.4219	YG-S21Y09	YG-S23Y09	YG-S24Y09	YG-S26Y09	YG-S28Y09	YG-S29Y09	
	27/64	10.8	.4252	YG-S21Y10	YG-S23Y10	YG-S24Y10	YG-S26Y10	YG-S28Y10	YG-S29Y10	
		11	.4331	YG-S21Y11	YG-S23Y11	YG-S24Y11	YG-S26Y11	YG-S28Y11	YG-S29Y11	
		Series Z Carbide Inserts								
Z 11.11mm (.437") to 12.95 (.510) 3/32 Thick	7/16	11.11	.4375	YG-S21Z01	YG-S23Z01	YG-S24Z01	YG-S26Z01	YG-S28Z01	YG-S29Z01	
		11.5	.4528	YG-S21Z02	YG-S23Z02	YG-S24Z02	YG-S26Z02	YG-S28Z02	YG-S29Z02	
		11.51	.4531	YG-S21Z03	YG-S23Z03	YG-S24Z03	YG-S26Z03	YG-S28Z03	YG-S29Z03	
	29/64	11.91	.4688	YG-S21Z04	YG-S23Z04	YG-S24Z04	YG-S26Z04	YG-S28Z04	YG-S29Z04	
		12	.4724	YG-S21Z05	YG-S23Z05	YG-S24Z05	YG-S26Z05	YG-S28Z05	YG-S29Z05	
		12.3	.4844	YG-S21Z06	YG-S23Z06	YG-S24Z06	YG-S26Z06	YG-S28Z06	YG-S29Z06	
	15/32	12.5	.4921	YG-S21Z07	YG-S23Z07	YG-S24Z07	YG-S26Z07	YG-S28Z07	YG-S29Z07	
		12.7	.5000	YG-S21Z08	YG-S23Z08	YG-S24Z08	YG-S26Z08	YG-S28Z08	YG-S29Z08	
		Series 0 Carbide Inserts								
	0 12.98 (.511") to 17.65 (.695") 1/8 Thick	33/64	13	.5118	YG-S21001	YG-S23001	YG-S24001	YG-S26001	YG-S28001	YG-S29001
			13.1	.5156	YG-S21002	YG-S23002	YG-S24002	YG-S26002	YG-S28002	YG-S29002
			13.49	.5313	YG-S21003	YG-S23003	YG-S24003	YG-S26003	YG-S28003	YG-S29003
17/32		13.5	.5315	YG-S21004	YG-S23004	YG-S24004	YG-S26004	YG-S28004	YG-S29004	
		13.89	.5469	YG-S21005	YG-S23005	YG-S24005	YG-S26005	YG-S28005	YG-S29005	
		14	.5512	YG-S21006	YG-S23006	YG-S24006	YG-S26006	YG-S28006	YG-S29006	
9/16		14.29	.5625	YG-S21007	YG-S23007	YG-S24007	YG-S26007	YG-S28007	YG-S29007	
		14.5	.5709	YG-S21008	YG-S23008	YG-S24008	YG-S26008	YG-S28008	YG-S29008	
		14.68	.5781	YG-S21009	YG-S23009	YG-S24009	YG-S26009	YG-S28009	YG-S29009	
37/64		15	.5906	YG-S21010	YG-S23010	YG-S24010	YG-S26010	YG-S28010	YG-S29010	
		15.08	.5938	YG-S21011	YG-S23011	YG-S24011	YG-S26011	YG-S28011	YG-S29011	
		15.48	.6094	YG-S21012	YG-S23012	YG-S24012	YG-S26012	YG-S28012	YG-S29012	
12.98 (.511") to 17.65 (.695") 1/8 Thick		15.5	.6102	YG-S21013	YG-S23013	YG-S24013	YG-S26013	YG-S28013	YG-S29013	
		15.7	.6181	YG-S21014	YG-S23014	YG-S24014	YG-S26014	YG-S28014	YG-S29014	
		15.88	.6250	YG-S21015	YG-S23015	YG-S24015	YG-S26015	YG-S28015	YG-S29015	
5/8		16	.6299	YG-S21016	YG-S23016	YG-S24016	YG-S26016	YG-S28016	YG-S29016	
		16.27	.6406	YG-S21017	YG-S23017	YG-S24017	YG-S26017	YG-S28017	YG-S29017	
		16.5	.6496	YG-S21018	YG-S23018	YG-S24018	YG-S26018	YG-S28018	YG-S29018	
41/64		16.67	.6563	YG-S21019	YG-S23019	YG-S24019	YG-S26019	YG-S28019	YG-S29019	
		17	.6693	YG-S21020	YG-S23020	YG-S24020	YG-S26020	YG-S28020	YG-S29020	
		17.07	.6719	YG-S21021	YG-S23021	YG-S24021	YG-S26021	YG-S28021	YG-S29021	
21/32		17.46	.6875	YG-S21022	YG-S23022	YG-S24022	YG-S26022	YG-S28022	YG-S29022	
		17.5	.6890	YG-S21023	YG-S23023	YG-S24023	YG-S26023	YG-S28023	YG-S29023	
		Series 1 Carbide Inserts								
1 17.53 (.690") to 24.38 (.960") 5/32 Thick	45/64	17.86	.7031	YG-S21101	YG-S23101	YG-S24101	YG-S26101	YG-S28101	YG-S29101	
		18	.7087	YG-S21102	YG-S23102	YG-S24102	YG-S26102	YG-S28102	YG-S29102	
		18.26	.7188	YG-S21103	YG-S23103	YG-S24103	YG-S26103	YG-S28103	YG-S29103	
	23/32	18.5	.7283	YG-S21104	YG-S23104	YG-S24104	YG-S26104	YG-S28104	YG-S29104	
		18.65	.7344	YG-S21105	YG-S23105	YG-S24105	YG-S26105	YG-S28105	YG-S29105	
		19	.7480	YG-S21106	YG-S23106	YG-S24106	YG-S26106	YG-S28106	YG-S29106	
	47/64	19.05	.7500	YG-S21107	YG-S23107	YG-S24107	YG-S26107	YG-S28107	YG-S29107	
		19.45	.7656	YG-S21108	YG-S23108	YG-S24108	YG-S26108	YG-S28108	YG-S29108	
		19.5	.7677	YG-S21109	YG-S23109	YG-S24109	YG-S26109	YG-S28109	YG-S29109	
	25/32	19.84	.7813	YG-S21110	YG-S23110	YG-S24110	YG-S26110	YG-S28110	YG-S29110	
		20	.7874	YG-S21111	YG-S23111	YG-S24111	YG-S26111	YG-S28111	YG-S29111	
		20.24	.7969	YG-S21112	YG-S23112	YG-S24112	YG-S26112	YG-S28112	YG-S29112	
	51/64	20.5	.8071	YG-S21113	YG-S23113	YG-S24113	YG-S26113	YG-S28113	YG-S29113	
		20.64	.8125	YG-S21114	YG-S23114	YG-S24114	YG-S26114	YG-S28114	YG-S29114	
		21	.8268	YG-S21115	YG-S23115	YG-S24115	YG-S26115	YG-S28115	YG-S29115	
	13/16	21.43	.8438	YG-S21116	YG-S23116	YG-S24116	YG-S26116	YG-S28116	YG-S29116	
		21.83	.8594	YG-S21117	YG-S23117	YG-S24117	YG-S26117	YG-S28117	YG-S29117	
		22	.8661	YG-S21118	YG-S23118	YG-S24118	YG-S26118	YG-S28118	YG-S29118	
	27/32	22.23	.8750	YG-S21119	YG-S23119	YG-S24119	YG-S26119	YG-S28119	YG-S29119	
		22.62	.8906	YG-S21120	YG-S23120	YG-S24120	YG-S26120	YG-S28120	YG-S29120	
		23	.9055	YG-S21121	YG-S23121	YG-S24121	YG-S26121	YG-S28121	YG-S29121	
	55/64	23.02	.9063	YG-S21122	YG-S23122	YG-S24122	YG-S26122	YG-S28122	YG-S29122	
		23.42	.9219	YG-S21123	YG-S23123	YG-S24123	YG-S26123	YG-S28123	YG-S29123	
		23.81	.9375	YG-S21124	YG-S23124	YG-S24124	YG-S26124	YG-S28124	YG-S29124	
7/8	24	.9449	YG-S21125	YG-S23125	YG-S24125	YG-S26125	YG-S28125	YG-S29125		
	24	.9449	YG-S21126	YG-S23126	YG-S24126	YG-S26126	YG-S28126	YG-S29126		
	24	.9449	YG-S21127	YG-S23127	YG-S24127	YG-S26127	YG-S28127	YG-S29127		

Call Us Today For All Of Your Machine Tool Needs!

2010-11 Master Catalog

SPADE DRILL INSERTS-CARBIDE

"THROW AWAY"
SPADE DRILL INSERTS

Carbide



Grade Information:

- C-5-Steel Cutting
- C-3- Cast Iron
- C-2- Ductile Iron
- Stainless Steel
- Aluminum
- Exotic Alloys

ALLIED™ "TA" Series Compatible!

Series Min-Max	Inch Dia	Metric Dia	Dec Dia	TIN C2 Part Number	TIALN C2 Part Number	Hardslick C2 Part Number	TIN C5 Part Number	TIALN C5 Part Number	Hardslick C5 art Number
Series 2 Carbide Inserts				\$39.40 ea.	\$42.47 ea.	\$38.61 ea.	\$39.40 ea.	\$42.47 ea.	\$38.61 ea.
2 24.41 (.961") to 35.05 (1.380") 3/16 Thick	31/32	24.61	.9688	YG-S21201	YG-S23201	YG-S24201	YG-S26201	YG-S28201	YG-S29201
	63/64	25	.9843	YG-S21202	YG-S23202	YG-S24202	YG-S26202	YG-S28202	YG-S29202
	1	25.4	1.0000	YG-S21203	YG-S23203	YG-S24203	YG-S26203	YG-S28203	YG-S29203
	1-1/64	25.8	1.0156	YG-S21204	YG-S23204	YG-S24204	YG-S26204	YG-S28204	YG-S29204
		26	1.0236	YG-S21205	YG-S23205	YG-S24205	YG-S26205	YG-S28205	YG-S29205
	1-1/32	26.19	1.0313	YG-S21206	YG-S23206	YG-S24206	YG-S26206	YG-S28206	YG-S29206
	1-3/64	26.59	1.0469	YG-S21207	YG-S23207	YG-S24207	YG-S26207	YG-S28207	YG-S29207
	1-1/16	26.99	1.0625	YG-S21208	YG-S23208	YG-S24208	YG-S26208	YG-S28208	YG-S29208
		27	1.0630	YG-S21209	YG-S23209	YG-S24209	YG-S26209	YG-S28209	YG-S29209
	1-3/32	27.78	1.0938	YG-S21210	YG-S23210	YG-S24210	YG-S26210	YG-S28210	YG-S29210
		28	1.1024	YG-S21211	YG-S23211	YG-S24211	YG-S26211	YG-S28211	YG-S29211
	1-7/64	28.18	1.1094	YG-S21212	YG-S23212	YG-S24212	YG-S26212	YG-S28212	YG-S29212
	1-1/8	28.58	1.1250	YG-S21213	YG-S23213	YG-S24213	YG-S26213	YG-S28213	YG-S29213
		29	1.1417	YG-S21214	YG-S23214	YG-S24214	YG-S26214	YG-S28214	YG-S29214
	1-5/32	29.37	1.1563	YG-S21215	YG-S23215	YG-S24215	YG-S26215	YG-S28215	YG-S29215
		30	1.1811	YG-S21216	YG-S23216	YG-S24216	YG-S26216	YG-S28216	YG-S29216
	1-3/16	30.16	1.1875	YG-S21217	YG-S23217	YG-S24217	YG-S26217	YG-S28217	YG-S29217
	1-7/32	30.96	1.2188	YG-S21218	YG-S23218	YG-S24218	YG-S26218	YG-S28218	YG-S29218
		31	1.2205	YG-S21219	YG-S23219	YG-S24219	YG-S26219	YG-S28219	YG-S29219
	1-1/4	31.75	1.2500	YG-S21220	YG-S23220	YG-S24220	YG-S26220	YG-S28220	YG-S29220
	32	1.2598	YG-S21221	YG-S23221	YG-S24221	YG-S26221	YG-S28221	YG-S29221	
1-9/32	32.54	1.2813	YG-S21222	YG-S23222	YG-S24222	YG-S26222	YG-S28222	YG-S29222	
	33	1.2992	YG-S21223	YG-S23223	YG-S24223	YG-S26223	YG-S28223	YG-S29223	
1-5/16	33.34	1.3125	YG-S21224	YG-S23224	YG-S24224	YG-S26224	YG-S28224	YG-S29224	
	34	1.3386	YG-S21225	YG-S23225	YG-S24225	YG-S26225	YG-S28225	YG-S29225	
1-11/32	34.13	1.3438	YG-S21226	YG-S23226	YG-S24226	YG-S26226	YG-S28226	YG-S29226	
1-3/8	34.93	1.3750	YG-S21227	YG-S23227	YG-S24227	YG-S26227	YG-S28227	YG-S29227	
	35	1.3780	YG-S21228	YG-S23228	YG-S24228	YG-S26228	YG-S28228	YG-S29228	
Series 3 Carbide Inserts				\$61.25 ea.	\$64.52 ea.	\$58.65 ea.	\$61.25 ea.	\$64.52 ea.	\$58.65 ea.
3 1.353 to 1.882 1/4 Thick	1-13/32	35.72	1.4063	YG-S21301	YG-S23301	YG-S24301	YG-S26301	YG-S28301	YG-S29301
		36	1.4173	YG-S21302	YG-S23302	YG-S24302	YG-S26302	YG-S28302	YG-S29302
	1-7/16	36.51	1.4375	YG-S21303	YG-S23303	YG-S24303	YG-S26303	YG-S28303	YG-S29303
		37	1.4567	YG-S21304	YG-S23304	YG-S24304	YG-S26304	YG-S28304	YG-S29304
	*1-15/32	37.31	1.4688	YG-S21305	YG-S23305	YG-S24305	YG-S26305	YG-S28305	YG-S29305
		38	1.4961	YG-S21306	YG-S23306	YG-S24306	YG-S26306	YG-S28306	YG-S29306
	1-1/2	38.1	1.5000	YG-S21307	YG-S23307	YG-S24307	YG-S26307	YG-S28307	YG-S29307
	1-17/32	38.89	1.5313	YG-S21308	YG-S23308	YG-S24308	YG-S26308	YG-S28308	YG-S29308
		39	1.5354	YG-S21309	YG-S23309	YG-S24309	YG-S26309	YG-S28309	YG-S29309
	1-9/16	40.48	1.5938	YG-S21310	YG-S23310	YG-S24310	YG-S26310	YG-S28310	YG-S29310
		40	1.5748	YG-S21311	YG-S23311	YG-S24311	YG-S26311	YG-S28311	YG-S29311
	1-19/32	40.48	1.5938	YG-S21312	YG-S23312	YG-S24312	YG-S26312	YG-S28312	YG-S29312
		41	1.6142	YG-S21313	YG-S23313	YG-S24313	YG-S26313	YG-S28313	YG-S29313
	1-5/8	41.28	1.6250	YG-S21314	YG-S23314	YG-S24314	YG-S26314	YG-S28314	YG-S29314
		42	1.6535	YG-S21315	YG-S23315	YG-S24315	YG-S26315	YG-S28315	YG-S29315
	1-21/32	42.07	1.6563	YG-S21316	YG-S23316	YG-S24316	YG-S26316	YG-S28316	YG-S29316
	1-11/16	42.86	1.6875	YG-S21317	YG-S23317	YG-S24317	YG-S26317	YG-S28317	YG-S29317
		43	1.6929	YG-S21318	YG-S23318	YG-S24318	YG-S26318	YG-S28318	YG-S29318
	1-23/32	43.66	1.7188	YG-S21319	YG-S23319	YG-S24319	YG-S26319	YG-S28319	YG-S29319
		44	1.7323	YG-S21320	YG-S23320	YG-S24320	YG-S26320	YG-S28320	YG-S29320
	1-3/4	44.45	1.7500	YG-S21321	YG-S23321	YG-S24321	YG-S26321	YG-S28321	YG-S29321
		45	1.7717	YG-S21322	YG-S23322	YG-S24322	YG-S26322	YG-S28322	YG-S29322
	1-25/32	45.24	1.7813	YG-S21323	YG-S23323	YG-S24323	YG-S26323	YG-S28323	YG-S29323
		46	1.8110	YG-S21324	YG-S23324	YG-S24324	YG-S26324	YG-S28324	YG-S29324
	1-13/16	4.04	1.8125	YG-S21325	YG-S23325	YG-S24325	YG-S26325	YG-S28325	YG-S29325
	1-27/32	46.83	1.8438	YG-S21326	YG-S23326	YG-S24326	YG-S26326	YG-S28326	YG-S29326
		47	1.8504	YG-S21327	YG-S23327	YG-S24327	YG-S26327	YG-S28327	YG-S29327
	1-7/8	47.63	1.8750	YG-S21328	YG-S23328	YG-S24328	YG-S26328	YG-S28328	YG-S29328

Prices Are
50%
Below Mfg's List!

- LATHES CHUCKS
- LIVE CENTERS
- WISE ACCESSORIES
- WISE JAWS
- STRAIGHT SHANK COLLET HOLDERS
- LATHES BUSHINGS
- DRILL CHUCKS
- CARBIDE INSERTS THREADING/GROOVING
- CUTTING TOOLS MACHINERY
- PRECISION TOOLS DEBURRING
- COOLANT/FLUIDS
- TOOL STORAGE

Call Us Or Visit Our Website For Our Complete Selection!

SPADE DRILL ACCESSORIES

TORX SCREWS & DRIVERS

Screws sold in packages of 10



Series	Torx Screw			Torx Screw (Nylon Locking)			Premium Torx Driver			Inch/Metric Drill Range	
	Item	Part Number	Price Per Pkg	Item	Part Number	Price Per Pkg	Item	Part Number	Price Each		
Y	2XT7	YG-J7Y001	\$12.99	2XT7N	YG-J7Y006	\$15.04	T7	YG-J5Y007	\$5.00	3/8 to 27/64	9 to 11
Z	2LXT7	YG-J7Z011	\$11.51	2LXT7N	YG-J7Z016	\$15.04	T7	YG-J5Y007	\$5.00	7/16 to 1/2	11.5 to 12.5
0	2.5XT8	YG-J80021	\$10.77	2.5XT8N	YG-J80026	\$14.11	T8	YG-J50008	\$5.00	33/64 to 11/16	13.0 to 17.5
0.5	2.5LXT8	YG-J80531	\$10.77	2.5LXT8N	YG-J80536	\$14.85	T8	YG-J50008	\$5.00	39/64 to 11/16	15.5 to 17.5
1	3XT9	YG-J91041	\$11.14	3XT9N	YG-J91046	\$14.11	T9	YG-J51009	\$5.00	45/64 to 15/16	18.0 to 24.0
1.5	3LXT9	YG-J91551	\$11.14	3LXT9N	YG-J91556	\$14.85	T9	YG-J51009	\$5.00	66/64 to 15/16	22.0 to 24.0
2	4XT15	YG-JB2061	\$10.77	4XT15N	YG-JB2066	\$14.85	T15	YG-J52015	\$5.00	31/32 to 1 3/8	25.0 to 35.0
2.5	4XT15	YG-JB2061	\$10.77	4XT15N	YG-JB2066	\$14.85	T15	YG-J52015	\$5.00	1 3/16 to 1 3/8	30.0 to 35.0
3 - 4	5XT20	YG-JC3081	\$10.77	5XT20N	YG-JC3086	\$14.85	T20	YG-J53020	\$5.00	1 13/32 to 2 9/16	36.0 to 65.0
5 - 8	6XT25	YG-JD5091	\$14.48	6XT25N	YG-JD5096	\$16.84	T25	YG-J55025	\$6.09	2 1/2 to 3 1/2	64.0 to 114.0

SPEEDS/FEEDS AND COATING RECOMMENDATIONS

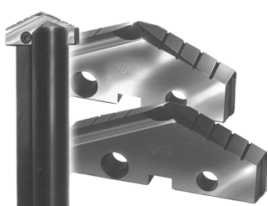

Material	Material Hardness (BHN)	Coating	SFM	Feed (IPR)						
				3/8" to 1/2"	33/64" to 11/16"	45/64" to 15/16"	31/32" to 1-3/8"	1-13/32" to 1-7/8"	1-29/32" to 2-9/16"	2-19/32" to 4-1/2"
Free Machining Steel 1118, 1215, 12L14, etc.	100-150	Super TiN Hardslick	280	.007	.010	.013	.016	.020	.023	.028
	150-200		260	.007	.010	.013	.016	.020	.023	.028
	200-250		240	.007	.010	.013	.016	.020	.023	.028
Low & Medium Carbon Steel 1018, 1040, 1140, etc.	125-175	Super TiALN Super TiN Hardslick	240	.006	.009	.012	.015	.019	.023	.027
	175-225		225	.005	.008	.010	.014	.018	.021	.024
	225-275		210	.005	.008	.010	.014	.018	.021	.024
Alloy Steel 4140, 5140, 8640, etc.	275-325	Super TiALN Super TiN	195	.004	.007	.009	.012	.016	.019	.022
	125-175		210	.006	.008	.010	.014	.017	.019	.022
	175-225		195	.005	.008	.010	.014	.017	.019	.022
High Strength Alloy Steel 4340, 4330V, 300M, etc.	225-300	Super TiALN	110	.005	.007	.009	.010	.014	.017	.020
	300-350		85	.004	.007	.009	.010	.014	.017	.020
	350-400		70	.003	.006	.008	.009	.012	.015	.018
Structural Steel A36, A285, A516, etc.	100-150	Super TiN	200	.006	.010	.012	.014	.018	.021	.026
	150-250		170	.005	.009	.010	.012	.016	.019	.024
	250-350		140	.004	.008	.009	.010	.014	.017	.020
High Temp. Alloy Hastelloy B, Inconel 600, etc.	140-220	Super TiALN Super TiN Hardslick	40	.003	.006	.007	.008	.010	.012	.015
	220-310		35	.003	.006	.007	.008	.010	.012	.015
Stainless Steel 303, 416, 420, 17-4 PH, etc.	135-185	Hardslick	105	.006	.008	.009	.011	.014	.016	.020
	185-275		90	.005	.007	.008	.010	.012	.014	.018
Tool Steel H-13, H021, A04, O-2, S-3, etc.	150-200	Super TiALN	110	.004	.006	.008	.010	.012	.015	.017
	200-250		90	.004	.006	.008	.010	.012	.015	.017
Aluminum	30	Hardslick	850	.008	.013	.016	.020	.022	.025	.025
	180		450	.008	.013	.016	.018	.022	.025	.025
Cast Iron Gray, Ductile, Nodular	120-150	Super TiALN	250	.007	.012	.016	.020	.024	.027	.030
	150-200		225	.006	.011	.014	.018	.022	.025	.028
	200-220		195	.006	.009	.012	.016	.018	.021	.024
	220-260		165	.005	.007	.009	.012	.014	.017	.020
	260-320		135	.004	.006	.007	.009	.012	.014	.016

Note: On many materials two or sometimes all three coatings will interchange with excellent performance.

Call Us Today For All Of Your Machine Tool Needs!