

T-SERIES LAYDOWN GROOVING INSERTS

GROOVING INSERTS

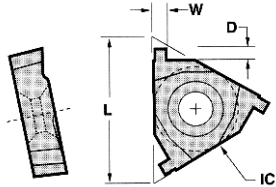

Full Line Available!
Please call for more information.



T SERIES LAYDOWN - EXTERNAL GROOVING INSERTS

W	IC	D	L	For Use With Holder	Left or Right	Grade GP50 Part Number	Price Each
0.047	0.375 (3/8)	0.07	0.65	16ER	RIGHT	T-16ERNGW47G50	\$15.17
0.062	0.375 (3/8)	0.08	0.65	16ER	RIGHT	T-16ERNGW62G50	\$15.17
0.093	0.375 (3/8)	0.07	0.65	16ER	RIGHT	T-16ERNGW93G50	\$15.17

T SERIES LAYDOWN - INTERNAL GROOVING INSERTS

W	IC	D	L	For Use With Holder	Left or Right	Grade GP50 Part Number	Price Each
0.047	0.375 (3/8)	0.07	0.65	16NR	RIGHT	T-16NRNGW47G50	\$15.17
0.062	0.375 (3/8)	0.08	0.65	16NR	RIGHT	T-16NRNGW62G50	\$15.17
0.093	0.375 (3/8)	0.07	0.65	16NR	RIGHT	T-16NRNGW93G50	\$15.17

THREADING INSERTS



T SERIES LAYDOWN - EXTERNAL THREADING INSERTS

Full Line Available!
Please call for more information.

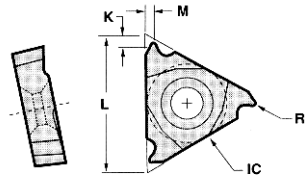

TPI If Threading	IC Both Threading & Grooving	L Both Threading & Grooving	IF THREADING			For Use With Holder	Left or Right	Grade AT22 Part Number	Price Each	Grade GP22 Part Number	Price Each	Grade GP50 Part Number	Price Each
			M	K	R								
16-48	3/8	0.65	0.031	0.024	0.003	16ER	RIGHT	T-16ERA60A2	\$12.12	T-16ERA60G22	\$11.42	T-16ERA60G50	\$11.42
						16EL	LEFT	T-16ELA60A2	\$12.12	-	-	-	
8-48	3/8	0.65	0.059	0.043	0.003	16ER	RIGHT	T-16ERAG60A2	\$12.12	T-16ERAG60G22	\$11.42	T-16ERAG60G50	\$11.42
						16EL	LEFT	T-16ELAG60A2	\$12.12	-	-	-	
8-14	3/8	0.65	0.059	0.043	0.007	16EL	LEFT	T-16ELG60A2	\$12.30	-	-	-	-
						22ER	RIGHT	-	-	-	-	T-22ERN60G50	\$13.20

T SERIES LAYDOWN - INTERNAL THREADING INSERTS

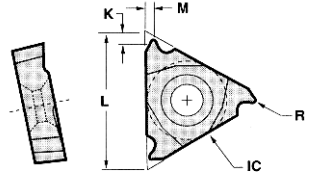

TPI If Threading	IC Both Threading & Grooving	L Both Threading & Grooving	IF THREADING			For Use With Holder	Left or Right	Grade AT22 Part Number	Price Each	Grade GP22 Part Number	Price Each	Grade GP50 Part Number	Price Each
			M	K	R								
16-48	3/8	0.65	0.031	0.024	0.003	16NR	RIGHT	-	-	-	-	T-16NRA60G50	11.42
						16NL	LEFT	-	-	-	-	T-16NLA60G50	11.42
8-48	3/8	0.65	0.059	0.043	0.003	16NR	RIGHT	T-16NRAG60A2	12.12	T-16NRAG60G22	11.42	T-16NRAG60G50	11.42
						16NL	LEFT	-	-	-	-	T-16NLAG60G50	11.42
8-14	3/8	0.65	0.059	0.043	0.007	16NR	RIGHT	-	-	T-16NRG60G22	11.42	T-16NRG60G50	11.42
						16NL	LEFT	-	-	-	-	T-16NLG60G50	11.42
5-7	1/2	0.87	0.098	0.067	0.01	16NR	RIGHT	-	-	T-22NRN60G22	13.20	T-22NRN60G50	13.20
						16NL	LEFT	-	-	-	-	T-22NLA60G50	13.20

Call Us Today For All Of Your Machine Tool Needs!

T-SERIES LAYDOWN THREADING HOLDERS

B

INTERNAL & EXTERNAL THREADING HOLDERS



LATHES CHUCKS
LIVE CENTERS

VICE JAWS
VICE ACCESSORIES

STRAIGHT SHANK
COLLET HOLDERS

LATHES BUSHINGS
DRILL CHUCKS

CARBIDE INSERTS
THREADING/GROOVING

CUTTING TOOLS
MACHINERY

PRECISION TOOLS
DEBURRING

COOLANT/FLUIDS
TOOL STORAGE



T SERIES LAYDOWN EXTERNAL THREADING HOLDERS

For Use With Holder	Left or Right	A	B	C	E	F	Part Number	Price Each
16ER	RIGHT	0.75	0.75	5	1.20	0.75	T-AL075-3R	\$68.35
	RIGHT	1.00	1.00	6	1.20	1.00	T-AL100-3R	\$73.97
22ER	RIGHT	1.00	1.00	6	1.42	1.00	T-AL100-4R	\$73.97
22EL	LEFT	1.00	1.00	6	1.42	1.00	T-AL100-4L	\$73.97
27ER	RIGHT	1.25	1.25	7	1.57	1.25	T-AL125-5R	\$82.96

T SERIES LAYDOWN INTERNAL THREADING HOLDERS

For Use With Holder	Left or Right	Min Bore For Boring Bars	C	D	F	L	Part Number	Price Each
16NR	RIGHT	0.625	2.50	0.63	0.312	7	T-NVR625-3R	\$90.63
	RIGHT	0.95	2.75	0.75	0.51	7	T-AVR750-3R	\$98.69
	RIGHT	1.15	3.00	1.00	0.64	10	T-AVR100-3R	\$98.69
	RIGHT	1.40	3.00	1.25	0.77	10	T-AVR125-3R	\$124.53
	RIGHT	1.70	3.00	1.50	0.90	12	T-AVR150-3R	\$130.15
22NR	RIGHT	1.10	2.75	0.75	0.61	7	T-NVR750-4R	\$90.63
	RIGHT	1.20	3.00	1.00	0.71	10	T-AVR100-4R	\$124.53

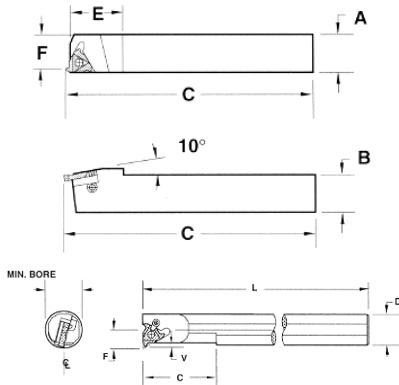

GRADE INFORMATION



Grade	Class	Description	Material	Application
GP4	C1/C5A K30/P30	Coated - Sub-Micron	Aluminum, Cast Iron, 300/400 Stainless Steel, Non-Metals, Carbon/Alloy Steel, Ductile Iron, Chrome	Extremely tough grades that perform well at very slow SFPM with minimal breakage or chipping.
GP22	C1 K30	Coated - Sub-Micron	Aluminum, Cast Iron, 300 Stainless Steel, High Temp Alloys, Non-Metals, Chrome	Extremely tough grades that perform well at very slow SFPM with minimal breakage or chipping.
GP3	C3	Coated - Sub-Micron	High Temp Alloys, 300 Stainless Steel	Versatile grades that combine high hardness with toughness
AT3	K15-K25 M05-M20	Coated - Sub-Micron	TiAlN Coated For High Temp Alloys & 300 Series Stainless Steel	-
GP50	C5	Coated	Carbon/Alloy Steel, 400 Stainless Steel, Ductile Iron	General purpose grades, coated grades can normally be ran at higher SFPM
AT50	P20-P35 M15-M30	Coated	TiAlN Coated For 400 Series Stainless Steel & Ductile Cast Iron	-
C3	C2-C3	Coated	Non Ferrous Metals, Plastics	-

COMBINATION THREAD & GROOVE TOOL

Thread and groove with the same tool!

- Micrograin carbide
- Right hand cutting
- Please specify groove width when ordering

Save Tool Change Time!

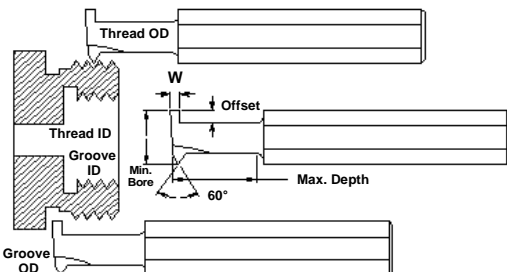

Tool ID No.	Max Depth	Groove W	Min Bore	Offset	Shank	OAL	Part Number	Price Each
TG-240-500	.500						IT-52-1100	
TG-240-750	.750	3/32 max	1/4	.050	1/4	2-1/2	IT-52-1105	\$51.69
TG-240-1000	1.000						IT-52-1110	
TG-310-500	.500						IT-52-1115	
TG-310-750	.750	1/8 max	5/16	.060	5/16	2-1/2	IT-52-1120	\$64.68
TG-310-1000	1.000						IT-52-1125	
TG-360-500	.500						IT-52-1130	
TG-360-750	.750	5/32 max	3/8	.080	3/8	2-1/2	IT-52-1135	\$79.29
TG-360-1000	1.000						IT-52-1140	

Call Us Or Visit Our Website For Our Complete Selection!

2010-11 Master Catalog

371