

# HYDRAULIC PRESSES/BRAKES

CHUCK JAWS  
LATHE WORKHOLDING

MACHINE VISES  
MAGNETIC CHUCKS

RETENTION KNOBS  
ER, DA, TG COLLETS

TOOLHOLDERS  
TAP HOLDERS

INDEXABLE DRILLS  
TURNING & BORING

ENDMILLS, DRILLS  
TAPS & REAMERS

ABRASIVES  
MEASURING TOOLS

MRO & SAFETY  
FLAT STOCK/DRILL ROD

## HYDRAULIC SHOP PRESSES

Hand Operated



- Hand operation for economical performance
- Rapid ram return starts as soon as release valve is opened and may be stopped at any point by closing the valve
- By-pass hole prevents excessive ram extension
- Adjustable table permits easy vertical movement by means of self-locking hoist
- Rapid screw traverse of ram permits quick, easy movement of the ram by means of a convenient handwheel
- Movable workhead is roller mounted on ball bearings for off-center positioning (except model 25H)

**NEW ITEM!**

**Full Line Available!**  
Please call for more information.

Capacity Tons	Mfg Model	Width Between Uprights	Width Between Table Channels	RAM Travel	Hor. Travel Workhead	Dimension Base x Height	Wgt	Part Number	Price Each
25	25H	33-1/2"	5-3/16"	5"	-	42-1/2" x 30" x 76"	450 lbs	DAKE-07001	\$2,950.00
50	50H	32-3/4"	7-1/4"	4"	20-3/4"	43-1/2" x 36" x 85"	810 lbs	DAKE-07002	\$3,995.00
75	75H	44"	8-1/4"	4-1/2"	29-5/8"	55" x 36" x 87"	1245 lbs	DAKE-07003	\$4,850.00
150	150G	48"	12-1/8"	8"	27-1/4"	66" x 42" x 95"	2750 lbs	DAKE-07005	\$13,595.00

## HYDRAULIC SHOP PRESSES

**NEW ITEM!**



- For pressing, bending and straightening operations
- Easy-to-use, hand-operated with pressure gauge for direct pressure readings
- Tables raise and lower easily with use of hand crank on 15, 35 and 60-ton models
- Side frames are open for inserting long material
- Fast setup ram extension screw

Call For Our Promotional Pricing!

**JET**

Part Number Price	JET-331406 \$1,250.00	JET-331416 \$2,199.00	JET-331431 \$3,850.00	JET-331460 \$9,350.00
Model	HP-5A	HP-15A	HP-35A	HP-60A
Capacity (tons)	5	15	35	60
Ram Diameter (in.)	1-3/4	2-1/2	3	5
Piston Stroke (in.)	4	4-1/2	4-3/4	5-1/2
Screw Stroke (in.)	3	3-1/8	4	4
Work Table (in.)	19 x 5-1/2	24-3/4 x 7-1/2	31 x 10-3/8	44-1/2 x 8
Lateral Move. (in.)	-	10-3/16	15	-
Vert Table Travel (in.)	15-3/4	22-3/16	23-5/8	29-1/2
Auxiliary Hand Press	-	-	-	1,000
Base Size (in.)	23-1/2 x 26	33-7/8 x 29-1/2	33-1/2 x 42	43-1/2 x 55-1/2
Height (in.)	51-1/2	65-1/2	68	78
Net Weight (lbs.)	192	435	783	1,570

## COMBINATION SHEAR, BRAKE AND ROLL

- Combination shear, brake and roll in one compact machine
- Right or left hand operation
- Shear can be used for mild steel, aluminum, brass, copper, lead, plastic and zinc
- Brake is equipped with easily removable fingers that permit angle, channel, box and other complex bending operations
- Slip rolls are precision turned and ground with wire grooves
- Set of male dies
- One set of female dies
- Dual edge shear blade
- Spring-loaded work hold down
- Back gauge

**NEW ITEM!**



**JET**

Part Number Price	JET-754031 \$845.00	JET-754041 \$1,224.00
Model	SBR-30N	SBR-40N
Shearing Cap. (mild steel) gauge x in.	20" x 30"	20" x 40"
Bending Cap. (mild steel) gauge x in.	20" x 30"	20" x 40"
Rolling Cap. (mild steel) gauge x in.	20" x 30"	20" x 40"
Size of Slip Roll (L x W)	30" x 1-1/2"	10" x 1-5/8"
Width of Upper Dies	1,2,3,6,8,10	1,1-1/2,2,2-1/2, 4,7,10,15
Upper Die Height	4-3/8"	3-3/8"
Net Weight	300 lbs	651 lbs

Call For Our Promotional Pricing!

## HORIZONTAL/VERTICAL BANDSAW

- Accurate cutting-Vibration free cast machined table bed, heavy steel base, horizontally mounted guide arms and adjustable blade guides and rollers
- Rugged gear bos-Bronze and steel gears, powering a fast-change, 4-speed, v-belt drive
- Hydraulic control for feeding stock at variable rates and to lock head at any height
- Quick release vise features hand wheel action for fast change of material sizes
- Wet/dry cutting with coolant pump system
- Sturdy steel base with wheels
- Vertical cutting table on model SE712

**DAKE**

**NEW ITEM!**



Part Number	DAKE-83100-1 \$1,425.00	DAKE-83101-1 \$2,100.00
Model Number	SE712	SE912
Cutting Capacity:		
Round Cap. at 90°	7"	9"
Round Cap. at 45°	4-1/2"	6"
Rectangle Cap. at 90°	7" x 12"	9" x 12"
Rectangle Cap. at 45°	4-1/2" x 7"	5" x 6"
Blade Size	3/4" X 93"	1" x 104-1/2"
Blade Speeds	85/130/180/235	98/164/246/328
Electrical	110V, 1PH	110V, 1PH
Motor	3/4 HP	1 HP

Call Us Today For All Of Your Machine Tool Needs!

# BANDSAWS

A

LATHES CHUCKS  
LIVE CENTERS

WISE JAWS  
WISE ACCESSORIES

STRAIGHT SHANK  
COLLET HOLDERS

LATHES BUSHINGS  
DRILL CHUCKS

CARBIDE INSERTS  
THREADING/GROOVING

CUTTING TOOLS  
MACHINERY

PRECISION TOOLS  
DEBURRING

COOLANT/LUIDS  
TOOL STORAGE

# JET

Part Number	JET-414458 \$425.00
Model Number	HVBS-56M
Cutting Capacity:	
Round Cap. at 90°	5"
Round Cap. at 45°	3"
Rectangle Cap. at 90°	5" x 6"
Rectangle Cap. at 45°	5" x 3"
Throat Depth	6"
Vertical Worktable	9-5/8" x 9-1/2"
Vise Swivels	45°
Blade Size	1/2" x .025" x 64-1/2"
Blade Wheel Diameter	7-3/8"
Blade Speeds	80, 120, 200
Motor	1/2HP, UL Listed, 115/230V,
Floor Space Required	42" x 18" x 44"
Net Weight	115 lbs



Call For Our Promotional Pricing!

## 5" x 6" HORIZONTAL/VERTICAL BANDSAW

### FEATURES:

- UL listed single phase motor
- Exclusive design heavy-duty 14-gauge stand
- Large diameter wheels and built-in handle allows easy movement
- Front legs feature adjustable leveling pads
- Ball bearing supported blade wheel
- Fully adjustable ball bearing blade guides
- Heat-treated and ground steel worm gear with bronze drive gear
- Three blade speeds to choose from
- Automatic shut-off after cut

### STANDARD EQUIPMENT

- Vertical worktable
- Carbon steel blade
- Adjustable material stop

## 7" x 12" HORIZONTAL/VERTICAL BANDSAW WITH COOLANT SYSTEM

Call For Our Promotional Pricing!

# JET

Part Number	JET-414459 \$1,222.00
Model Number	HVBS-7MW
Cutting Capacity:	
Round Cap. at 90°	7"
Round Cap. at 45°	4-1/2"
Rectangle Cap. at 90°	7" x 8-1/2"
Rectangle Cap. at 45°	7" x 5"
Throat Depth	7"
Vertical Worktable	9-3/8" x 10"
Vise Swivels	45°
Blade Size	3/4 x .035 x 93
Blade Wheel Dia.	11-3/4"
Blade Speeds (SFPM)	80, 130, 180, 285
Bed Height	23"
Motor	3/4HP, 1Ph, 115/230V, Prewired 115V
Floor Space Required	20-1/2" x 49-1/2"
Net Weight	318 lbs



### FEATURES

- UL listed motor
- Heavy cast iron bow and bed
- Hydraulic downfeed for ease of cut
- Hardened and ground worm gear
- Roller cabinet with built-in chip tray
- Automatic shut-off after cut

### STANDARD EQUIPMENT

- Vertical worktable
- Coolant system
- 3/4" Bi-metal blade
- Adjustable material stop
- Chip brush

**Starrett**  
Bandsaw Blades are  
on pages 472-475

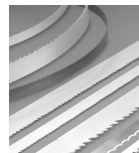

## 8" X 13" HORIZONTAL BANDSAW



# WILSON

**Full Line Available!**  
Please call for more information.

Part Number	WI-7015
	\$3,380.00
Round @ 90°	8-1/2"
Round @ 45°	8-1/2"
Rectangle @ 90°	8-1/2" x 13"
Rectangle @ 45°	8-1/2" x 9-3/4"
Motor	1.5HP, 115/230V, 1 Ph, prewired 115V
Blade Speeds (SFPM)	82, 132, 170, 235
Vertical Worktable	9-3/8" x 10"
Blade Size	1" x .035 x 114.5"
Bed Height	27-1/2"
Floor Space Required	62-1/2" x 23" x 48"
Net Weight	551 lbs

### FEATURES:

- Heavy-duty, rigid steel and cast iron construction of the head and base provides full blade support and eliminates vibration and deflection
- The combination of an oil bath, gear reduction power train, along with precision blade guides and hydraulic feed system delivers consistent, accurate cuts and longer blade life

## 7" X 12" HORIZONTAL BANDSAW

Ideal product for machine, maintenance and fabricating shops and for limited run machine production work!

### STANDARD FEATURES

- Blade Guides: Side: Eccentric shaft, ball bearing, Rear: Ball bearings
- Blade drive is steel, heat treated worm, driving a bronze worm gear in oil bath
- Heavy duty cast iron saw head and table
- Oil bath hardened and ground worm gear
- Adjustable ball bearing blade guides
- Blade wheels are made of flanged cast iron
- Adjustable hydraulic feed system
- Automatic shut-off at end of cut

### STANDARD EQUIPMENT

- Rapid acting vise
- Coolant Pump 1 gallon, 1 Ph motor.
- Wet cutting models complete with hose, flexible nozzle, shut-off valve, tank and baffle.

PART NUMBER	WI-3400 (Dry)	WI-3410 (Wet)
	\$1,199.00	\$1,249.00
Round at 90°	7"	7"
Round at 45°	6"	6"
Rectangle at 90°	10" x 7"	10" x 7"
Rectangle at 45°	6" x 7"	6" x 7"
Blade Size	3/4" x .032 x 93"	3/4" x .032" x 93"
Blade Wheel Speeds (SFPM)	86,132,178,260	86,132,178,260
Blade Wheels	11-7/16"	11-7/16"
Height of Work Table	23-1/2"	23-1/2"
Motor	3/4HP, 115v, 1pH,1725rpm	3/4HP, 115v, 1pH,1725rpm
Overall Dimensions	50" x 18" x 41"	50" x 18" x 41"
Net Weight	330 lbs	346 lbs



Call Us Or Visit Our Website For Our Complete Selection!

2010-11 Master Catalog

489

# BANDSAWS

## 8" x 14" HORIZONTAL GEAR HEAD BANDSAW

Call For Our Promotional Pricing!



**FEATURES:**

- Easy accessible control panel
- Hydraulic feed
- Portable on wheels
- Hardened and ground worm gears
- Miters at 45°
- Quick action vise

**STANDARD EQUIPMENT**

- Coolant system
- 3/4" Carbon steel blade
- Adjustable material stop
- Chip brush

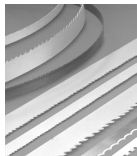

**Starrett**  
Bandsaw Blades are  
on pages 472-475



**PART NUMBER**

**JET-414466**  
**\$1,999.00**

Model Number	HBS-814GH
Round at 90°	8"
Round at 45°	6-1/2"
Rectangle at 90°	14" x 8"
Rectangle at 45°	6-1/2" x 4-1/2"
Vise Swivels	45°
Blade Size	3/4" x .035" x 97"
Blade Speeds (SFPM)	135, 197, 256
Blade Wheel Diameter	12"
Bed Height	26"
Motor	1HP, 115/230V, 1Ph, Prewired 115
Floor Space Required	51-1/2" x 18-1/8" x 44"
Net Weight	287 lbs

## 9" & 10" HORIZONTAL BANDSAWS

FINANCING AVAILABLE!



**FEATURES:**

- Large handwheel and built-in gauge for easy blade tensioning
- Coolant is distributed through blade guides
- Blade guides feature parallel double row ball bearing support
- Blade brush is built-in and self-propelled
- Quick-positioning vise with fully adjustable jaws swivels to 45°
- Removable chip tray for quick clean-up
- Blade is fully guarded regardless of blade guide position
- Fully adjustable hydraulic downfeed with separate on/off valve

**STANDARD EQUIPMENT**

- Automatic shut-off after cut
- Carbide blade guides with rollers
- Coolant system
- 4/6VT Bi-metal blade
- Adjustable material stop



Model JET-414468 Shown

**PART NUMBER**

<b>9" x 16"</b>	<b>10" x 18"</b>
<b>JET-414468</b>	<b>JET-414473</b>
<b>\$4,475.00</b>	<b>\$4,899.00</b>

Model Number	HBS-916W	HBS-1018W
Cutting Capacity:		
Round Cap. at 90°	9"	10"
Round Cap. at 45°	9"	10"
Rectangle Cap. at 90°	2" x 16" - 9" x 14"	10" x 15"
Rectangle Cap. at 45°	9" x 6-1/8"	10" x 7-1/4"
Vise Swivels	45°	45°
Blade Size	1" x .035" x 119-1/2"	1" x .035" x 130-1/2"
Blade Wheel Diameter	13"	14"
Blade Speeds (SFPM)	82, 132, 170, 235	82, 132, 210, 330
Bed Height	25"	25"
Motor	1-1/2 HP, 1 Ph, 115/230V, Prewired 11 5V	2HP, 230V only, 1Ph
Floor Space Required	65" x 28" x 42"	70" x 31" x 44"
Net Weight	625 lbs	776 lbs

Call For Our Promotional Pricing!

## 12" x 20" HORIZONTAL BANDSAW SEMI-AUTOMATIC

Full Line Available!  
Please call for more information.



**FEATURES:**

- Variable speed drive system allows the operator to fine-tune the blade speed quickly and easily
- Exclusive swivel control panel
- Heave-duty transmission utilizes hardened and ground gears operating in an oil bath



Call For Our Promotional Pricing!

**Part Number**

**WI-7060**  
**\$9,599.00**

Round @ 90 & 45° Cap.	12"
Rectangle @ 90°	12" x 20"
Rectangle @ 45°	12" x 12"
Motor	3HP, 230/460V, 3 Ph
Blade Speeds (SFPM)	82 to 262
Blade Size	1" x .035 x 156"
Blade Wheels	17
Net Weight	1456 lbs

## 13" SEMI-AUTOMATIC SWIVEL HEAD MITER BANDSAW

FINANCING AVAILABLE!



**Features:**

- Advanced hydraulic system provides dependable power for powered clamping and raising the saw head at end of cut
- Full stroke machine vise for tight clamping of any material from operator's panel
- Swivel sawhead allows the operator to accurately pivot head for angle cuts from 0° for a 90° cut to 60°
- Variable blade speed
- Power chip brush removes chip from the blade extending blade life
- Integrated coolant system
- Drive Motor: 3HP
- Blade Size 1" x .035" x 13'7"

**NEW ITEM!**



**PART NUMBER**

**CLAUS-MS1318SA**  
**\$9,455.00**

Round @ 90°	13"
Square @ 90°	10.6"
Round @ 45°	11.5"
Square @ 45°	10.5"
Blade Speeds	102-377 FPM
Motor	3HP
Blade Size	1" x .035" x 13' 7"
Shipping Weight	1850 lbs.

Call Us Today For All Of Your Machine Tool Needs!

# BANDSAWS/COLD SAWS

A

## 10" X 16" MITER BANDSAWS

**FINANCING AVAILABLE!**

**JET**

LATHES CHUCKS  
LIVE CENTERS

WISE JAWS  
WISE ACCESSORIES

STRAIGHT SHANK  
COLLET HOLDERS

LATHES BUSHINGS  
DRILL CHUCKS

CARBIDE INSERTS  
THREADING/GROOVING

CUTTING TOOLS  
MACHINERY

PRECISION TOOLS  
DEBURRING

COOLANT/FLUIDS  
TOOL STORAGE

**FEATURES:**

- Variable speed drive system allows the operator to fine tune the blade speed fast and easily
- Exclusive 6 contact point blade adjustable guide assemblies
- Combined with the side bearings are carbide pads, the back of the blade rides on two load bearings mounted on a pivot shaft so both bearings share the load equally
- Mitering head - the workpiece remains fixed while the head swivels to cut any angle 0°-45°
- Heavy duty transmission utilizes hardened and ground gears operating in an oil bath
- Counterbalanced feed system is controlled by a dual system of counterbalance springs working with a hydraulic cylinder.
- Swing away control panel
- Cast iron blade wheels
- Coolant system
- 1" Bi-metal blade
- Adjustable material stop

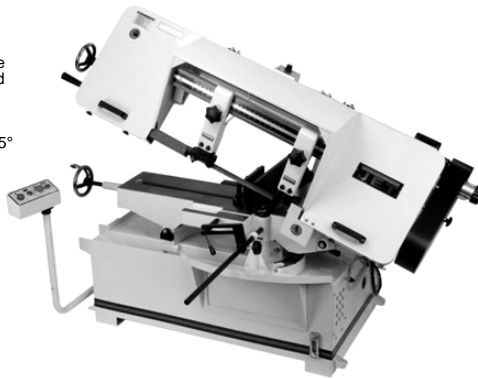

**Call For Our Promotional Pricing!**

**Full Line Available!**  
Please call for more information.

PART NUMBER	JET-414474 <b>\$6,639.00</b>	JET-414475 <b>\$6,639.00</b>
Model Number	J-7020M	J-7040M
Round Capacity at 90°	10"	10"
Rectangle Capacity at 90°	9" x 16"	9" x 16"
Blade Size	1" x .035 x 135"	1" x .035 x 135"
Blade Speeds (SFPM)	100-350	100-350
Motor	1-1/2 HP, 1 Ph, 115/230V	2 HP, 3 Ph, 220V
Net Weight	1125 lbs	1125 lbs

## 14" & 16" VERTICAL BANDSAWS

**FINANCING AVAILABLE!**

**JET**

**FEATURES:**

- Specially designed for shop or production use, including the cutting of ferrous type materials
- Heavy-duty, completely enclosed steel frame
- Variable speeds provide proper adjustments for high efficiency cutting
- Multi-tilting worktable
- Easy to read blade tension indicator

**FEATURES OF JET-414485**

- Designed for a multitude of uses in the shop or production line, including the cutting of both ferrous and non-ferrous
- Two-speed gear box and variable speeds provide quick setting and allow proper adjustment for high efficiency cutting
- Increased accuracy is possible with the rip fence, which can be used on either side of the blade

**STANDARD EQUIPMENT**

- Blade welder, grinder, and cutter
- Worklamp
- Chip blower
- 1/4" x 14/18VT Bi-metal blade
- Blade and tire cleaning brush
- Set of tools



**Call For Our Promotional Pricing!**

VERTICAL BANDSAWS	14"	16"
PART NUMBER	JET-414483 <b>\$4,725.00</b>	JET-414485 <b>\$6,499.00</b>
Model Number	VBS-1408	VBS-1610
Cutting Capacity:		
Height	8"	10"
Throat	14"	15-1/2"
Blade Length (approx.)	114"	123-1/2"
Blade Width (min.-max.)	1/8"-1/2"	1/8"-5/8"
Blade Speeds (SFPM)	82 - 330	Low 82 to 330; High 985-3950
Table Size	20" x 20"	22" x 24"
Table Tilt	8° F & B, 12° L & 15° R	8° F & B, 12° L & 15° R
Table Height at 90°	39"	40"
Welder (KVA)	1.5	1.5
Motor	1HP, 115/230V, 1Ph, Prewired 115V	2HP, 230/460V, 3Ph, Prewired 230V
Floor Space Required	34" x 24" x 68-1/2"	37" x 28" x 72-1/2"
Net Weight (lbs.)	580 lbs	900 lbs

## MANUAL CIRCULAR COLD SAWS

**FEATURES:**

- Head rotates 45° right and left of center for mitering.
- Adjustable hinged pivot.
- Dependable oversized spindle and gear assembly with steel spindle and bronze gear.
- Additional ball bearing support of hardened and ground spindle shaft to prevent failure.
- Bronze gear with tapered roller bearing support.
- Reliable mechanical coolant pump with flow control adjustment.

**STANDARD EQUIPMENT**

- Blade
- Gallon of coolant
- Pedestal base
- Adjustable positive stop and tool kit



**DAKE**

PART NUMBER	DAKE-74250 <b>\$2,850.00</b>	DAKE-74315 <b>\$4,650.00</b>
Model	Cut 250	Super Cut...315CE
Voltage	*110-volt	*220-volt
Maximum Blade Dia	10"	12"
Motor (hp)	1.2	2.5
Speeds (rpm)	44	22/44
Work Height	37"	38-1/2"
Height	61"	59"
Floor Space	21" X 20-1/4"	26" X 23"
Solid Round 90° Cap.	1-1/4"	2-5/8"
Solid Round 45° Cap.	1"	2-1/2"
Tube 90° Cap.	2-3/4	3-5/8"
Tube 45° Cap.	2-3/8	3-1/2"
Square 90° Cap.	2-1/2	3-1/4"
Square 45° Cap.	2-1/8	3-1/8"
Rectangle 90° Cap.	3-7/8" x 1-3/4"	4-1/4" x 2-3/4"
Rectangle 45° Right Cap.	2-1/2" x 1-7/8"	3-1/4" x 2-3/4"
Weight	378 lbs	410 lbs

**Full Line Available!**  
Please call for more information.

**Call Us Or Visit Our Website For Our Complete Selection!**